

FW
P3.00

HW
04



IS117 Rev.27 26/08/2025

B70/1DC

centrale di comando 24V per cancelli scorrevoli

Istruzioni originali

ROGER
BRUSHLESS



- IT - Istruzioni ed avvertenze per l'installatore
- EN - Instructions and warnings for the installer
- DE - Anweisungen und Hinweise für den Installateur
- FR - Instructions et consignes pour l'installateur
- ES - Instrucciones y advertencias para el instalador
- PT - Instruções e advertências para o instalador
- NL - Aanwijzingen en waarschuwingen voor de installateur
- PL - Instrukcja i ostrzeżenia dla instalatora

ROGER
TECHNOLOGY

FW
P3.00

HW
04

Dispositivo IP B74/BCONNECT
B74/BCONNECT IP device

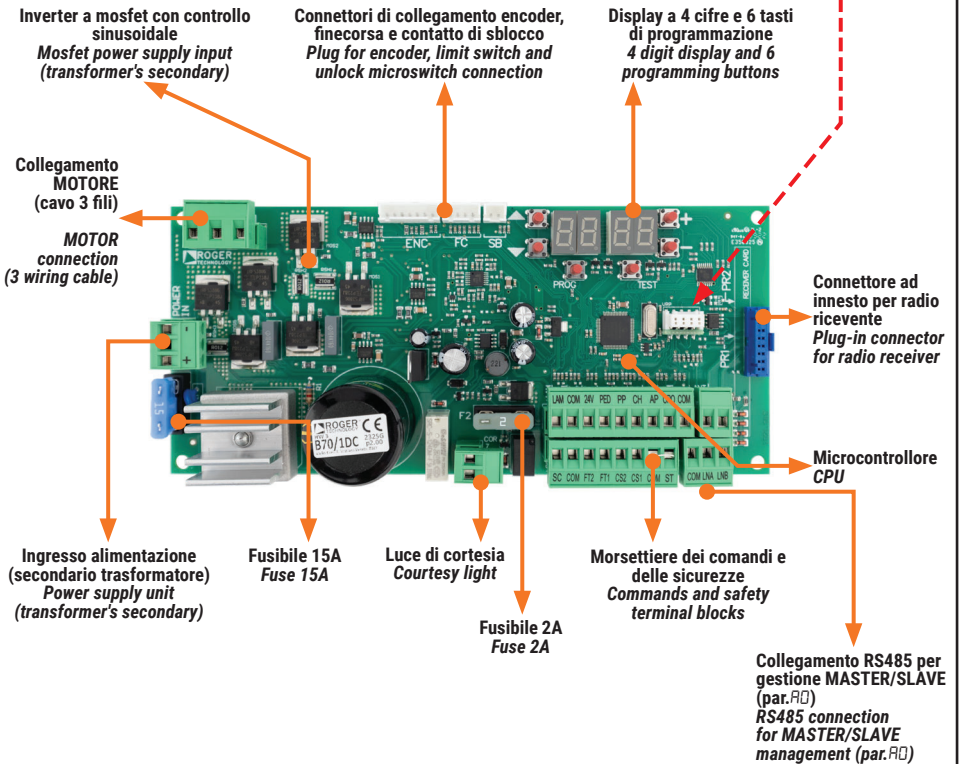
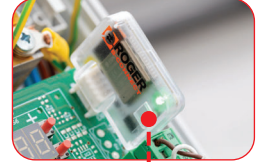

1

BH30

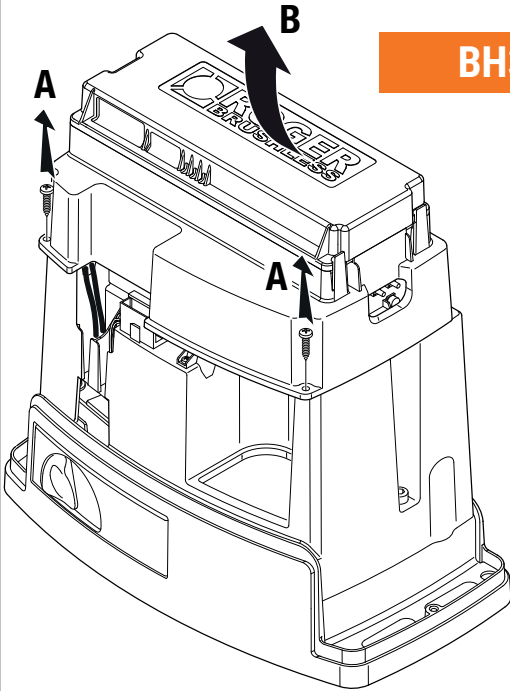

BM30

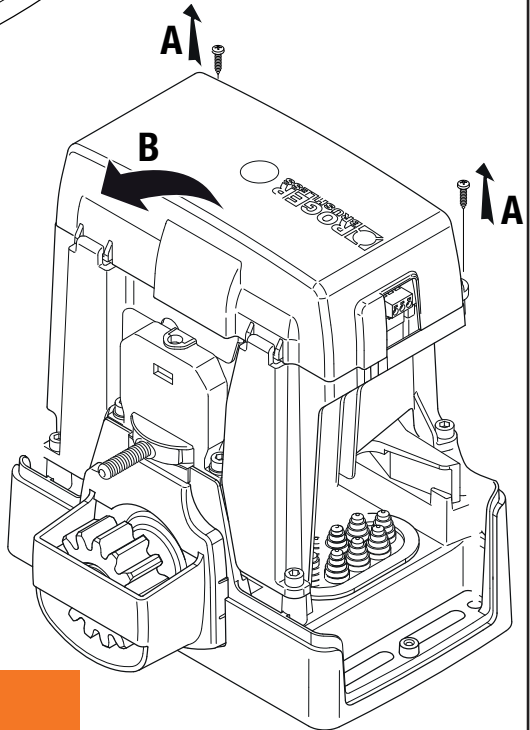

BH30 • Scheda ricarica batteria B71/BC / B71/BC battery charger

2

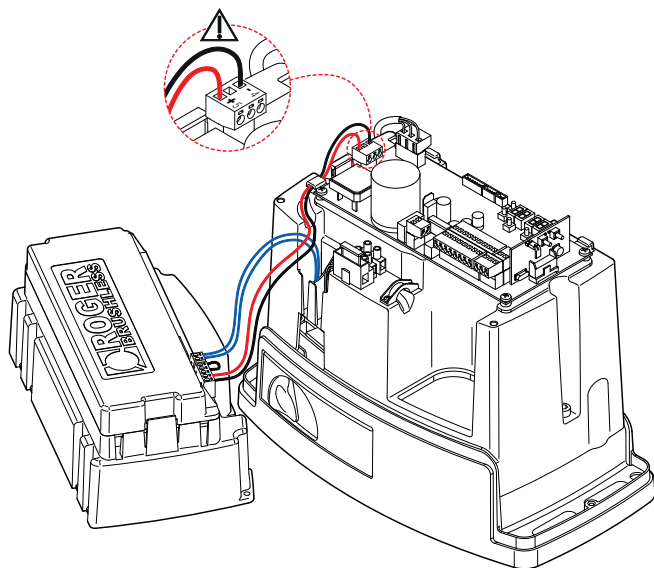
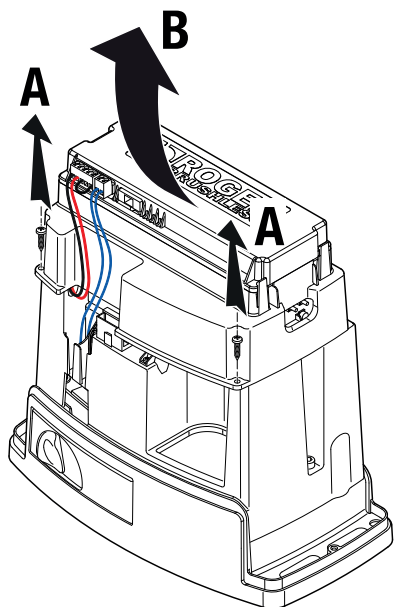

L'utilizzo è possibile solo disabilitando la modalità low-power (L 1 00).
Use is only possible by disabling low-power mode (L 1 00).

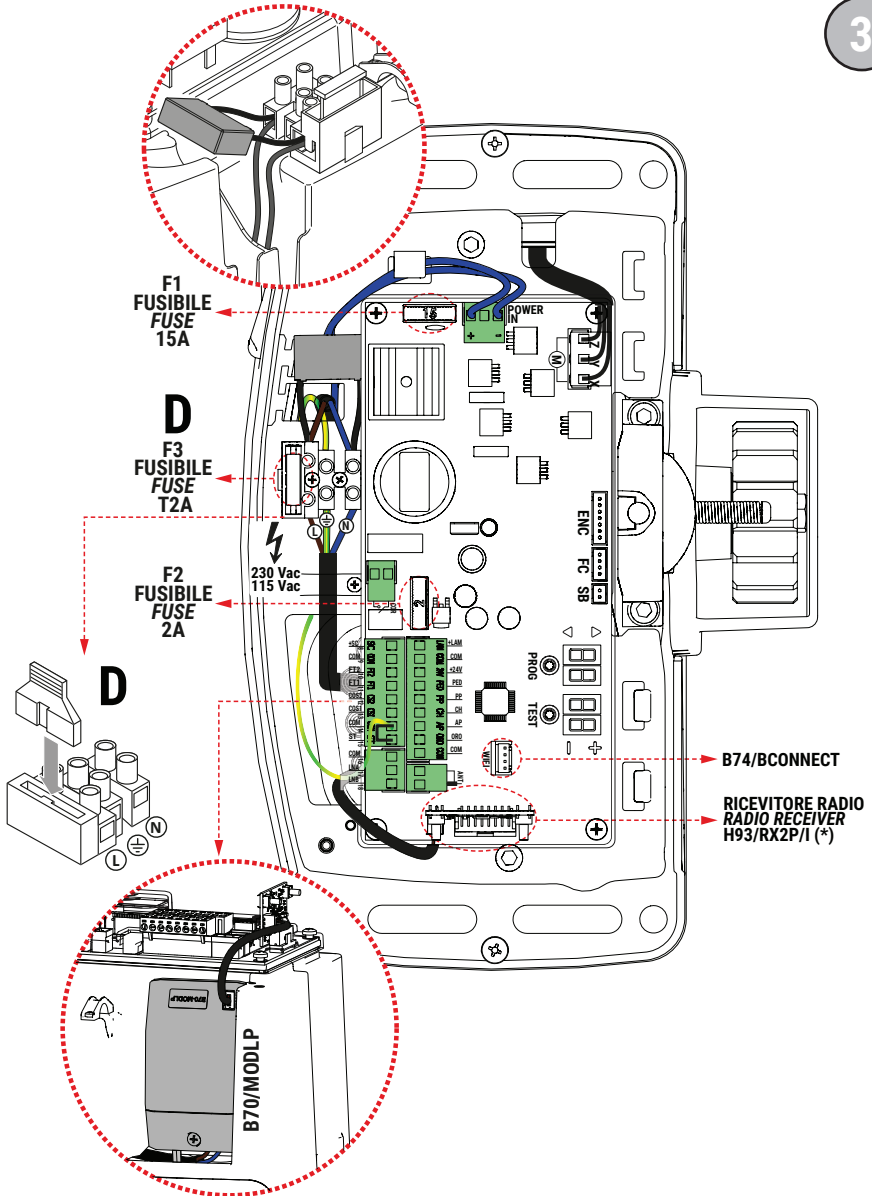

(*) Avvalendosi del dispositivo B70/MODLP collegato mediante cablaggio a 3 fili al ricevitore H93/RX2LP/1, la centrale controlla lo stato di funzionamento entrando dopo un tempo di inattività prestabilito nella modalità "low power" / Using the B70/MODLP device connected via 3-wire cabling to the H93/RX2LP/1 receiver, the control unit monitors the operating status by entering "low power" mode after a preset idle time

BH30

4

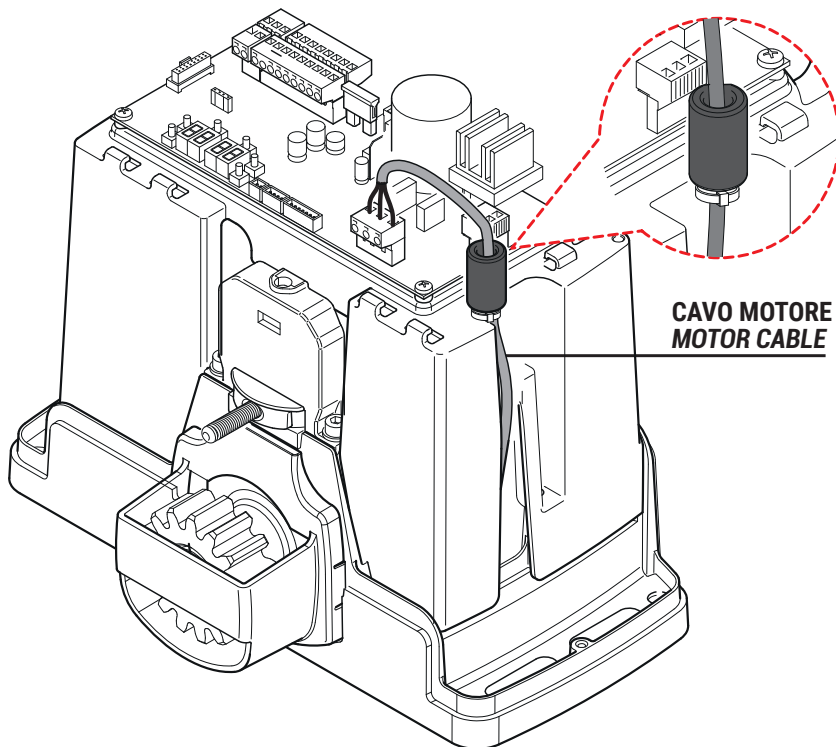
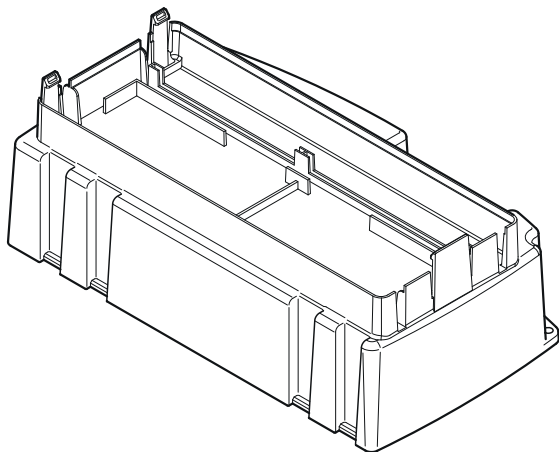

CAVO MOTORE
MOTOR CABLE

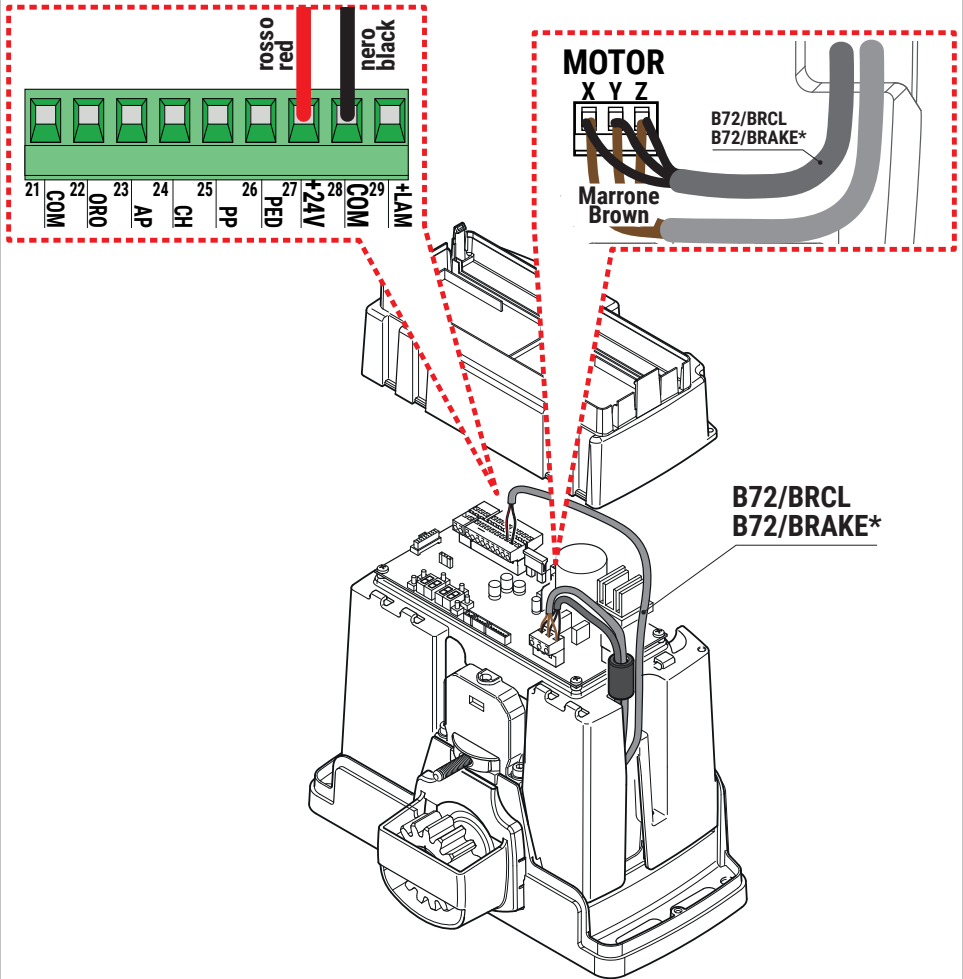

(*)

Il **B72/BRCL** sostituisce il **B72/BRAKE** • The **B72/BRCL** replaces the **B72/BRAKE** • Die **B72/BRCL** ersetzt die **B72/BRAKE** • Le **B72/BRCL** remplace le **B72/BRAKE** • El **B72/BRCL** reemplaza al **B72/BRAKE** • O **B72/BRCL** substitui o **B72/BRAKE**



BH30/804/R

6

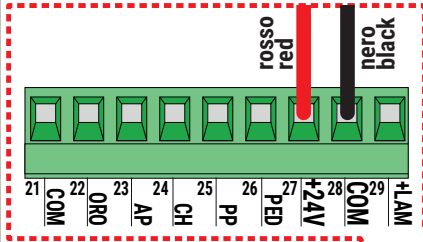

NON COLLEGATO
NOT CONNECTED

MOTOR

X Y Z

B72/BRCL
B72/BRAKE*

Marrone Brown

B72/BRCL
B72/BRAKE*

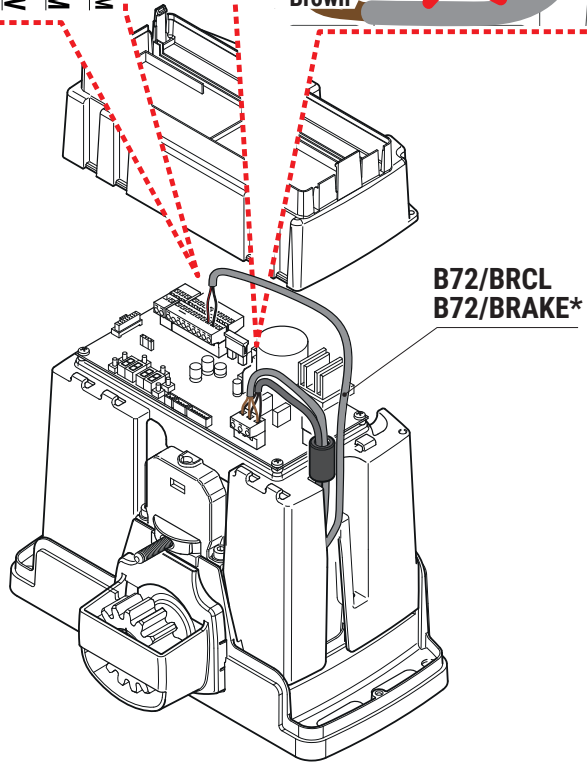

BM30

7

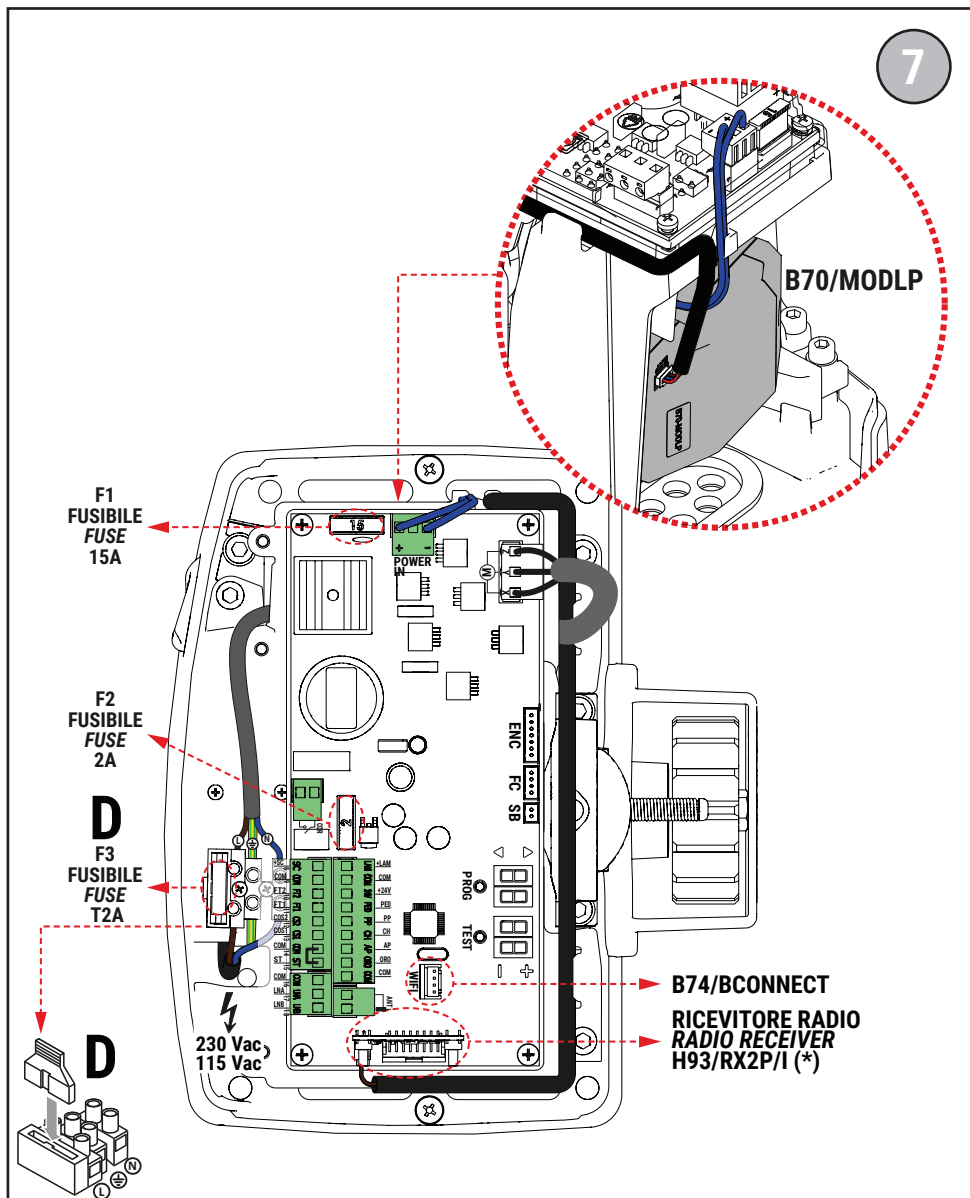

(*) Avvalendosi del dispositivo B70/MODLP collegato mediante cablaggio a 3 fili al ricevitore H93/RX2LP/I, la centrale controlla lo stato di funzionamento entrando dopo un tempo di inattività prestabilito nella modalità "low power" / Using the B70/MODLP device connected via 3-wire cabling to the H93/RX2LP/I receiver, the control unit monitors the operating status by entering "low power" mode after a preset idle time



BM30 High Speed

8

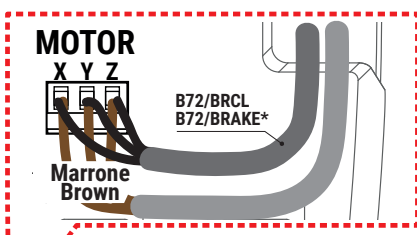
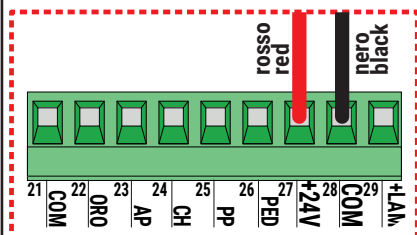

Cavo motore
Motor cable

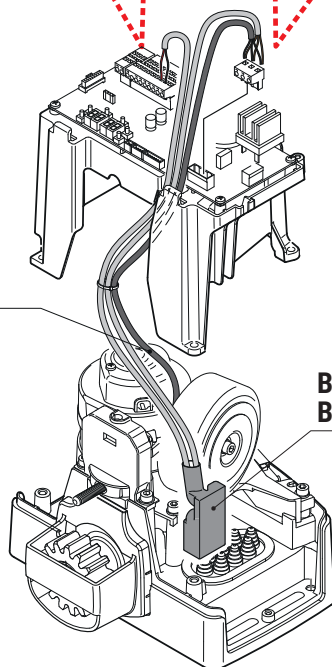

B72/BRCL
B72/BRAKE *



(*)

Il **B72/BRCL** sostituisce il **B72/BRAKE** • The **B72/BRCL** replaces the **B72/BRAKE** • Die **B72/BRCL** ersetzt die **B72/BRAKE** • Le **B72/BRCL** remplace le **B72/BRAKE** • El **B72/BRCL** reemplaza al **B72/BRAKE** • O **B72/BRCL** substitui o **B72/BRAKE**

BH30 • BM30

9

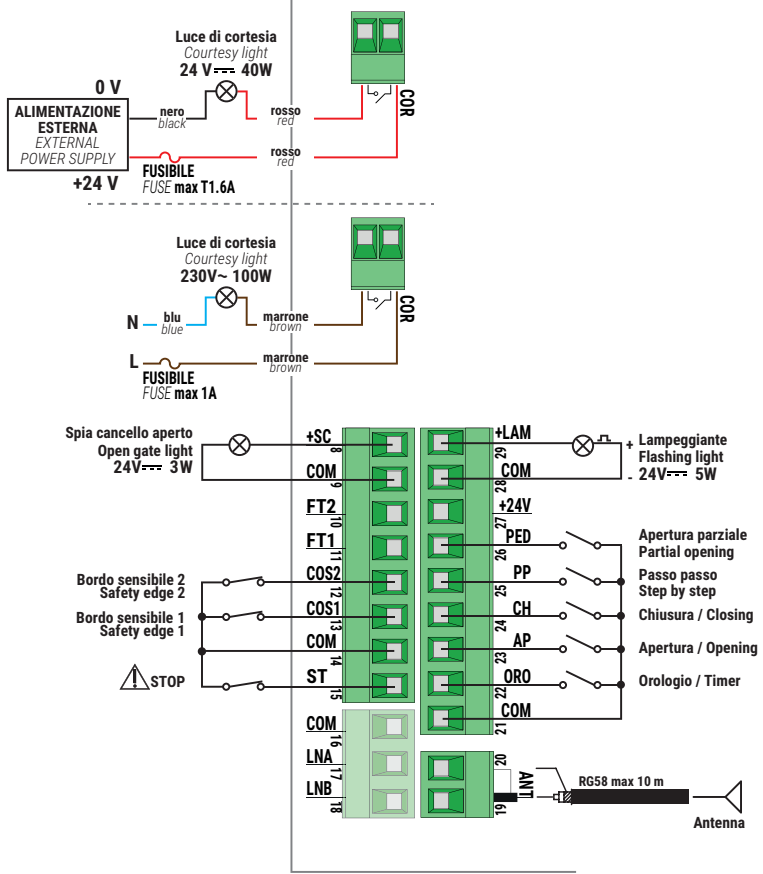

Utilizzo alternativo dell'uscita COR (par.20 diverso da 00).
 Alternative use of COR output (par.20 different from 00).

10

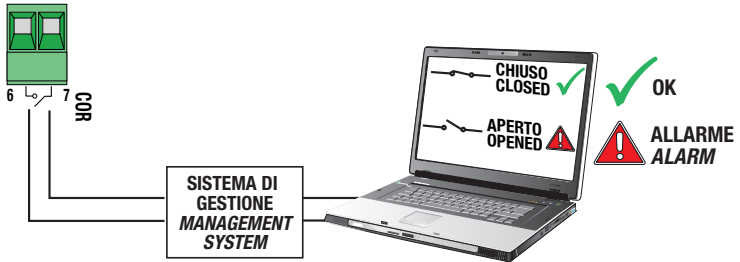

L'utilizzo è possibile solo disabilitando la modalità low-power (L 1 00)
 Use is only possible by disabling low-power mode (L 1 00)

COLLEGAMENTO CON 1 COPPIA FOTOCELLULE SINCRONIZZATE (MODALITÀ NORMALE, SOLO COPPIA MASTER)
CONNECTION WITH 1 SYNCHRONISED PHOTOCELL PAIR (NORMAL MODE, MASTER PAIR ONLY)

ROSSO = libero da jumper
 RED = jumper free

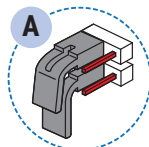
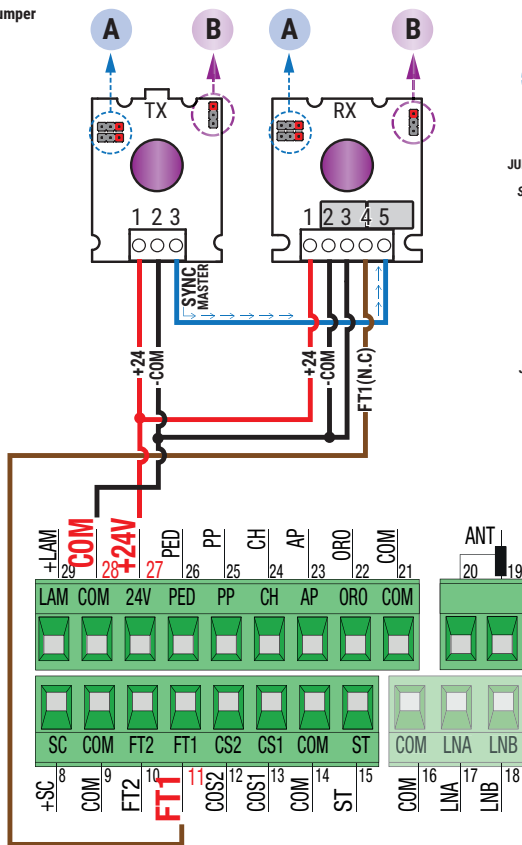

JUMPER DI SINCRONIZZAZIONE (PER MASTER)
SYNCHRONISATION JUMPER (FOR MASTER)

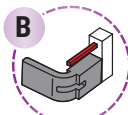

JUMPER DI ALLINEAMENTO (PER MASTER) OFF*
ALIGNMENT JUMPER (FOR MASTER) OFF*

11

* Per eseguire la modalità in di allineamento ottico
 (NOTA: consultare le istruzioni delle fotocellule):
 * To perform optical alignment mode
 (NOTE: refer to photocell instructions):

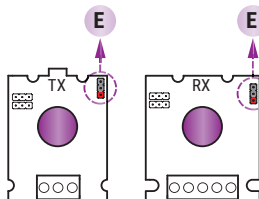

JUMPER DI ALLINEAMENTO ON*
ALIGNMENT JUMPER ON*



ATTENZIONE! Modificare la posizione dei jumper di sincronizzazione o di allineamento solamente quando le fotocellule sono **NON ALIMENTATE!** La configurazione scelta con i jumper viene memorizzata dalle fotocellule solamente all'accensione delle fotocellule.

Scollegare la morsetteria della centrale che fornisce alimentazione alle fotocellule, oppure togliere completamente la tensione al controller digitale (scollegando, se presenti, anche le batterie di backup) e verificare nella fotocellula TX / RX che il LED rosso di alimentazione sia spento; procedere soltanto ora all'impostazione della configurazione dei jumper.

ATTENTION! Please ensure that the photocell jumpers are only changed with the power to the control panel switched off, including the disconnection of any battery backup. Remove the terminal of the photocell inputs or completely remove the voltage from the digital controller (check that the digital controller is not powered by backup batteries) and check that the TX / RX photocell red power LED is off.

SI RACCOMANDA L' USO DI fotocellule Serie F4ES - F4S / RECOMMENDED USE for Series F4ES - F4S photocells

COLLEGAMENTO CON 2 COPPIE FOTOCELLE SINCROZZATE (MODALITÀ NORMALE, 1 MASTER E 1 SLAVE)
CONNECTION WITH 2 SYNCHRONISED PHOTOCELL PAIRS (NORMAL MODE, 1 MASTER AND 1 SLAVE)

ROSSO = libero da jumper
 RED = jumper free

12

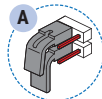
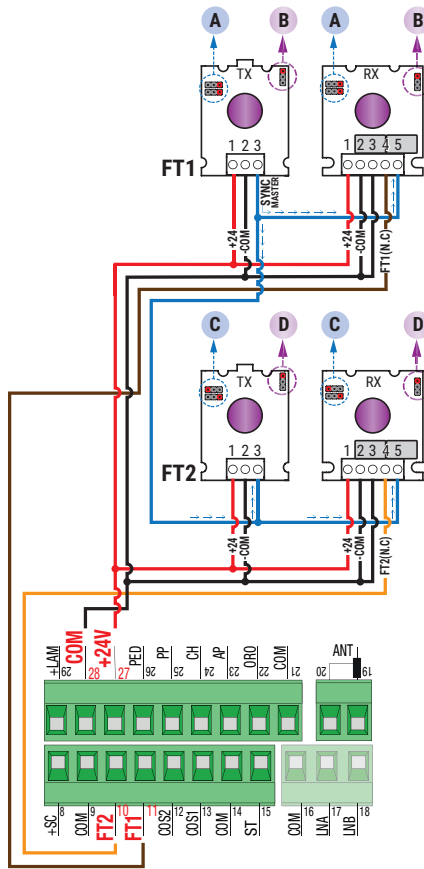

JUMPER DI SINCROZZAZIONE (PER MASTER)
SYNCHRONISATION JUMPER (FOR MASTER)



JUMPER DI ALLINEAMENTO (PER MASTER) OFF*
ALIGNMENT JUMPER (FOR MASTER) OFF*

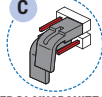

JUMPER DI SINCROZZAZIONE (PER SLAVE1)
SYNCHRONISATION JUMPER (FOR SLAVE1)



JUMPER DI ALLINEAMENTO (PER SLAVE1) OFF*
ALIGNMENT JUMPER (FOR SLAVE1) OFF*

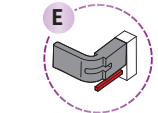
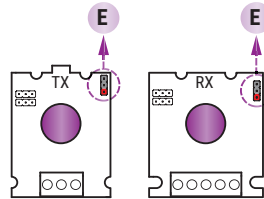

JUMPER DI ALLINEAMENTO ON*
ALIGNMENT JUMPER ON*

* Per eseguire la modalità in di allineamento ottico
 (NOTA: consultare le istruzioni delle fotocelle):
 * To perform optical alignment mode
 (NOTE: refer to photocell instructions):



ATTENZIONE! Modificare la posizione dei jumper di sincronizzazione o di allineamento solamente quando le fotocelle sono **NON ALIMENTATE!** La configurazione scelta con i jumper viene memorizzata dalle fotocelle solamente all'accensione delle fotocelle.

Scollegare la morsetteria della centrale che fornisce alimentazione alle fotocelle, oppure togliere completamente la tensione al controller digitale (scollegando, se presenti, anche le batterie di backup) e verificare nella fotocella TX / RX che il LED rosso di alimentazione sia spento; procedere soltanto ora all'impostazione della configurazione dei jumper.

ATTENTION! Please ensure that the photocell jumpers are only changed with the power to the control panel switched off, including the disconnection of any battery backup. Remove the terminal of the photocell inputs or completely remove the voltage from the digital controller (check that the digital controller is not powered by backup batteries) and check that the TX / RX photocell red power LED is off.

SI RACCOMANDA L' USO DI fotocelle Serie F4ES - F4S / RECOMMENDED USE for Series F4ES - F4S photocells

TEST FOTOCELLE · PHOTOCELLS TEST (AB 02)

COLLEGAMENTO CON 1 COPPIA FOTOCELLE SINCRONIZZATE (MODALITÀ NORMALE, SOLO COPPIA MASTER) CONNECTION WITH 1 SYNCHRONISED PHOTOCCELL PAIR (NORMAL MODE, MASTER PAIR ONLY)

ROSSO = libero da jumper
RED = jumper free

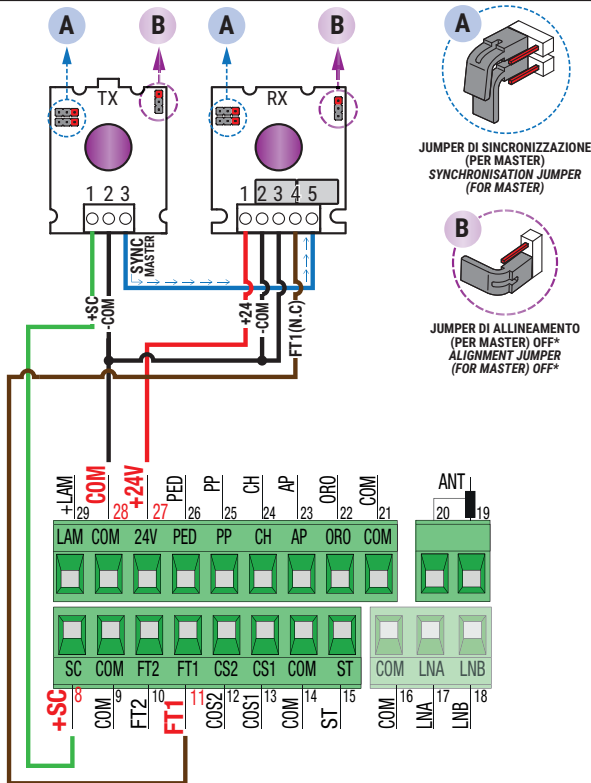

13

* Per eseguire la modalità in di allineamento ottico
(NOTA: consultare le istruzioni delle fotocelle):
* To perform optical alignment mode
(NOTE: refer to photocell instructions):

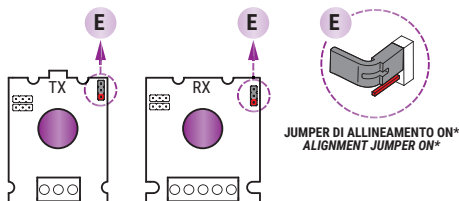

ATTENZIONE! Modificare la posizione dei jumper di sincronizzazione o di allineamento solamente quando le fotocelle sono **NON ALIMENTATE!** La configurazione scelta con i jumper viene memorizzata dalle fotocelle solamente all'accensione delle fotocelle.

Scollegare la morsetteria della centrale che fornisce alimentazione alle fotocelle, oppure togliere completamente la tensione al controller digitale (scollegando, se presenti, anche le batterie di backup) e verificare nella fotocella TX / RX che il LED rosso di alimentazione sia spento; procedere soltanto ora all'impostazione della configurazione dei jumper.

ATTENTION! Please ensure that the photocell jumpers are only changed with the power to the control panel switched off, including the disconnection of any battery backup. Remove the terminal of the photocell inputs or completely remove the voltage from the digital controller (check that the digital controller is not powered by backup batteries) and check that the TX / RX photocell red power LED is off.

SI RACCOMANDA L' USO DI fotocelle Serie F4ES - F4S / RECOMMENDED USE for Series F4ES - F4S photocells

TEST FOTOCELLE · PHOTOCELLS TEST (AB 02)

COLLEGAMENTO CON 2 COPPIE FOTOCELLE SINCRONIZZATE (MODALITÀ NORMALE, 1 MASTER E 1 SLAVE) CONNECTION WITH 2 SYNCHRONISED PHOTOCCELL PAIRS (NORMAL MODE, 1 MASTER AND 1 SLAVE)

ROSSO = libero da jumper
RED = jumper free

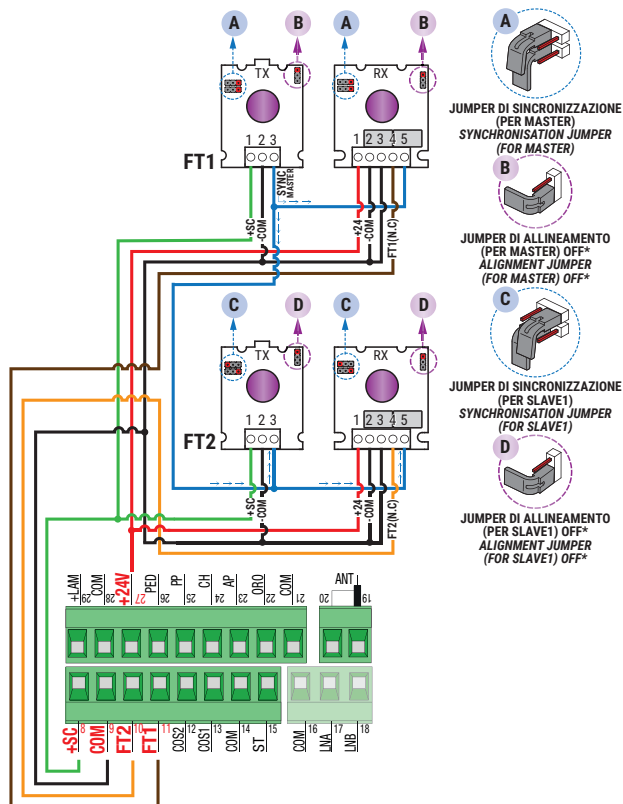

14

JUMPER DI SINCRONIZZAZIONE (PER MASTER)
SYNCHRONISATION JUMPER (FOR MASTER)

JUMPER DI ALLINEAMENTO (PER MASTER) OFF*
ALIGNMENT JUMPER (FOR MASTER) OFF*

JUMPER DI SINCRONIZZAZIONE (PER SLAVE)
SYNCHRONISATION JUMPER (FOR SLAVE)

JUMPER DI ALLINEAMENTO (PER SLAVE) OFF*
ALIGNMENT JUMPER (FOR SLAVE) OFF*

* Per eseguire la modalità in di allineamento ottico
(NOTA: consultare le istruzioni delle fotocelle):
* To perform optical alignment mode
(NOTE: refer to photocell instructions):

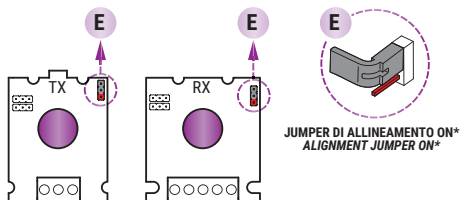

ATTENZIONE! Modificare la posizione dei jumper di sincronizzazione o di allineamento solamente quando le fotocelle sono **NON ALIMENTATE!** La configurazione scelta con i jumper viene memorizzata dalle fotocelle solamente all'accensione delle fotocelle.

Scollegare la morsetteria della centrale che fornisce alimentazione alle fotocelle, oppure togliere completamente la tensione al controller digitale (scollegando, se presenti, anche le batterie di backup) e verificare nella fotocella TX / RX che il LED rosso di alimentazione sia spento; procedere soltanto ora all'impostazione della configurazione dei jumper.

ATTENTION! Please ensure that the photocell jumpers are only changed with the power to the control panel switched off, including the disconnection of any battery backup. Remove the terminal of the photocell inputs or completely remove the voltage from the digital controller (check that the digital controller is not powered by backup batteries) and check that the TX / RX photocell red power LED is off.

SI RACCOMANDA L'USO DI fotocelle Serie F4ES - F4S / RECOMMENDED USE for Series F4ES - F4S photocells

BATTERY SAVING (AB 03)

BATTERY SAVING + TEST FOTOCELLULE · PHOTOCELLS TEST (AB 04)

COLLEGAMENTO CON 1 COPPIA FOTOCELLULE SINCRONIZZATE (MODALITÀ NORMALE, SOLO COPPIA MASTER) CONNECTION WITH 1 SYNCHRONISED PHOTOCCELL PAIR (NORMAL MODE, MASTER PAIR ONLY)

ROSSO = libero da jumper
RED = jumper free

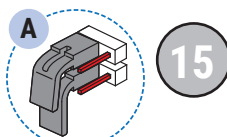
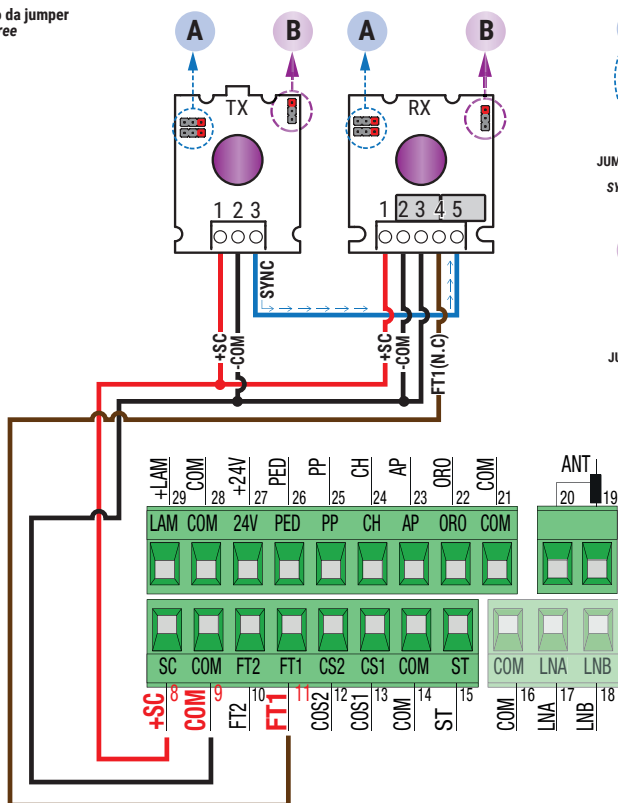

JUMPER DI SINCRONIZZAZIONE (PER MASTER)
SYNCHRONISATION JUMPER (FOR MASTER)

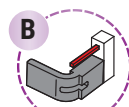

JUMPER DI ALLINEAMENTO (PER MASTER) OFF*
ALIGNMENT JUMPER (FOR MASTER) OFF*

* Per eseguire la modalità in di allineamento ottico
(NOTA: consultare le istruzioni delle fotocellule):
* To perform optical alignment mode
(NOTE: refer to photocell instructions):

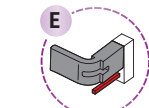
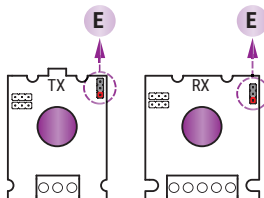

JUMPER DI ALLINEAMENTO ON*
ALIGNMENT JUMPER ON*



ATTENZIONE! Modificare la posizione dei jumper di sincronizzazione o di allineamento solamente quando le fotocellule sono **NON ALIMENTATE!** La configurazione scelta con i jumper viene memorizzata dalle fotocellule solamente all'accensione delle fotocellule.

Scollegare la morsetteria della centrale che fornisce alimentazione alle fotocellule, oppure togliere completamente la tensione al controller digitale (scollegando, se presenti, anche le batterie di backup) e verificare nella fotocellula TX / RX che il LED rosso di alimentazione sia spento; procedere soltanto ora all'impostazione della configurazione dei jumper.

ATTENTION! Please ensure that the photocell jumpers are only changed with the power to the control panel switched off, including the disconnection of any battery backup. Remove the terminal of the photocell inputs or completely remove the voltage from the digital controller (check that the digital controller is not powered by backup batteries) and check that the TX / RX photocell red power LED is off.

SI RACCOMANDA L' USO DI fotocellule Serie **F4ES - F4S** / **RECOMMENDED USE for** Series **F4ES - F4S** photocells

BATTERY SAVING (AB 03)

BATTERY SAVING + TEST FOTOCELLULE · PHOTOCELLS TEST (AB 04)

COLLEGAMENTO CON 2 COPPIE FOTOCELLULE SINCRONIZZATE (MODALITÀ NORMALE, 1 MASTER E 1 SLAVE) CONNECTION WITH 2 SYNCHRONISED PHOTOCELL PAIRS (NORMAL MODE, 1 MASTER AND 1 SLAVE)

ROSSO = libero da jumper
RED = jumper free

16

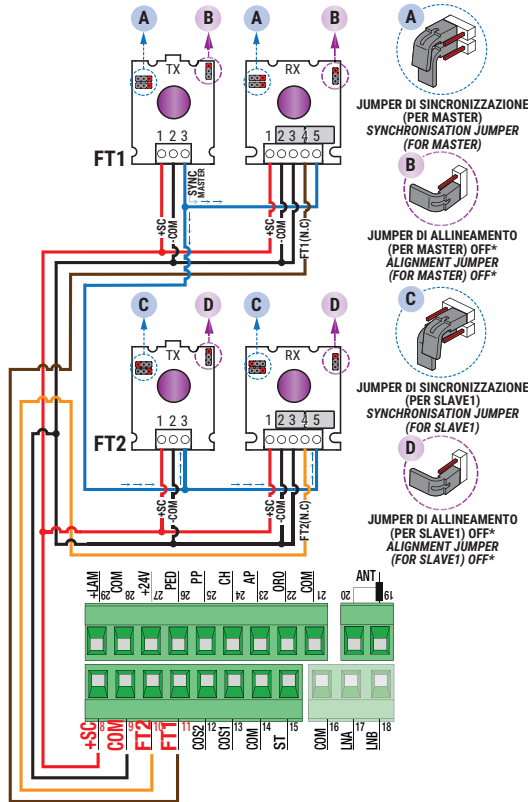

A
JUMPER DI SINCRONIZZAZIONE (PER MASTER)
SYNCHRONISATION JUMPER (FOR MASTER)

B
JUMPER DI ALLINEAMENTO (PER MASTER) OFF*
ALIGNMENT JUMPER (FOR MASTER) OFF*

C
JUMPER DI SINCRONIZZAZIONE (PER SLAVE1)
SYNCHRONISATION JUMPER (FOR SLAVE1)

D
JUMPER DI ALLINEAMENTO (PER SLAVE1) OFF*
ALIGNMENT JUMPER (FOR SLAVE1) OFF*

* Per eseguire la modalità in di allineamento ottico
(NOTA: consultare le istruzioni delle fotocellule):
* To perform optical alignment mode
(NOTE: refer to photocell instructions):

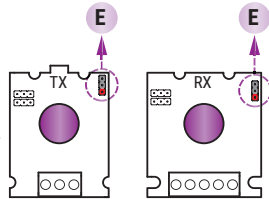

E
JUMPER DI ALLINEAMENTO ON*
ALIGNMENT JUMPER ON*



ATTENZIONE! Modificare la posizione dei jumper di sincronizzazione o di allineamento solamente quando le fotocellule sono **NON ALIMENTATE!** La configurazione scelta con i jumper viene memorizzata dalle fotocellule solamente all'accensione delle fotocellule.

Scollegare la morsetteria della centrale che fornisce alimentazione alle fotocellule, oppure togliere completamente la tensione al controller digitale (scollegando, se presenti, anche le batterie di backup) e verificare nella fotocellula TX / RX che il LED rosso di alimentazione sia spento; procedere soltanto ora all'impostazione della configurazione dei jumper.

ATTENTION! Please ensure that the photocell jumpers are only changed with the power to the control panel switched off, including the disconnection of any battery backup. Remove the terminal of the photocell inputs or completely remove the voltage from the digital controller (check that the digital controller is not powered by backup batteries) and check that the TX / RX photocell red power LED is off.

SI RACCOMANDA L' USO DI fotocellule Serie **F4ES - F4S** / **RECOMMENDED USE for** Series **F4ES - F4S** photocells

17

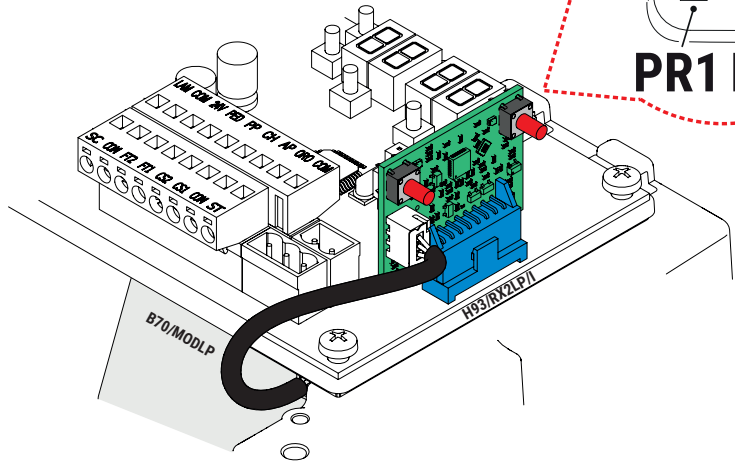
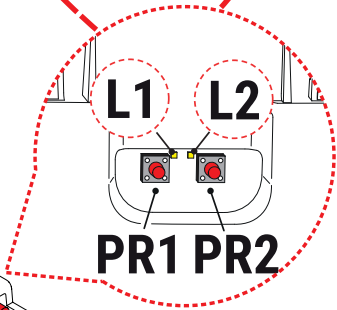
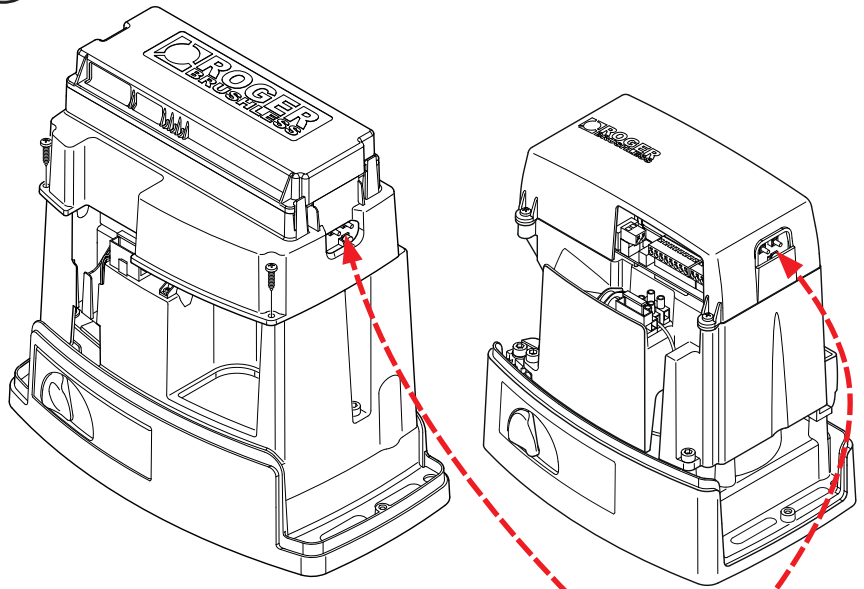

PR1/PR2: Canali radio / Radio channels

BH30

18

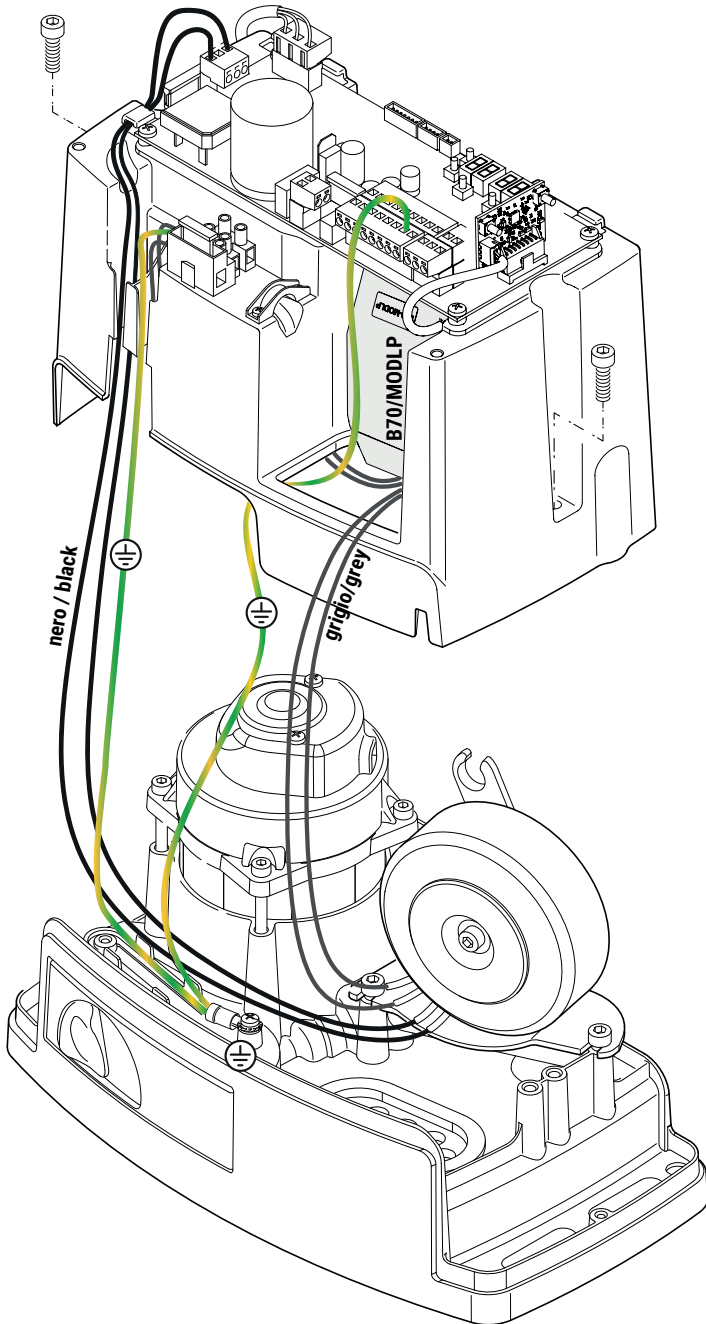

BM30

19

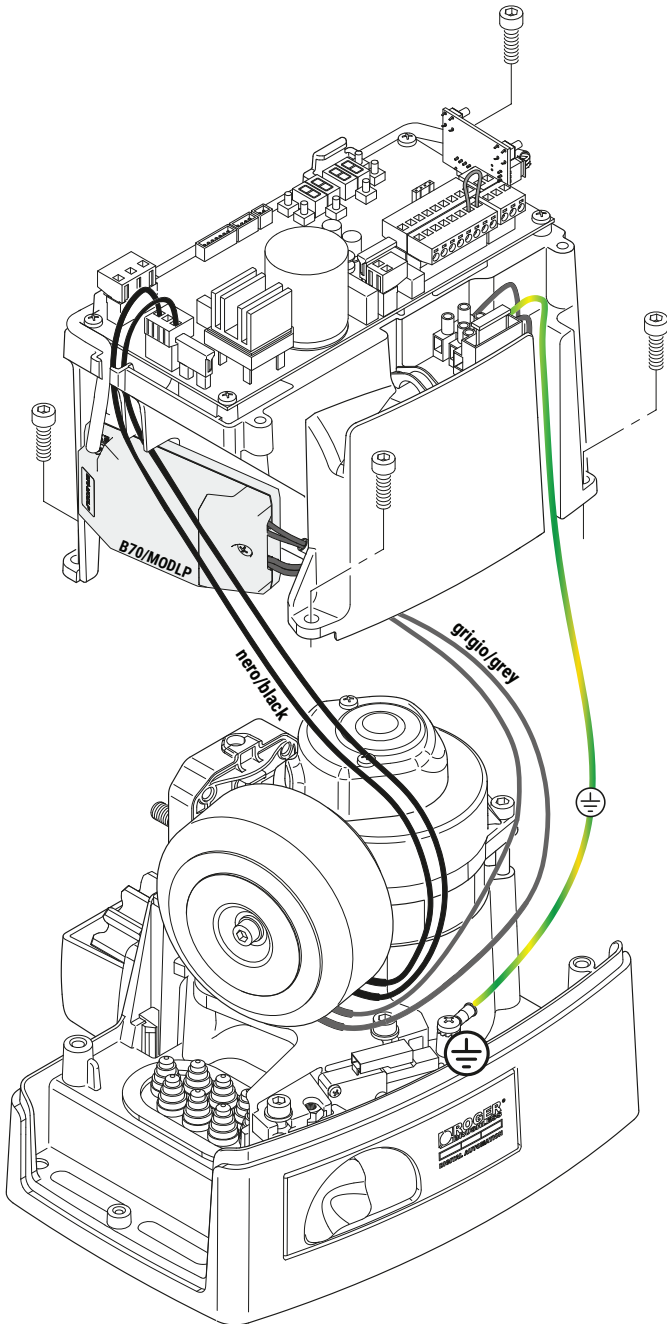

FINECORSA MECCANICO
MECHANICAL LIMIT
SWITCH

20

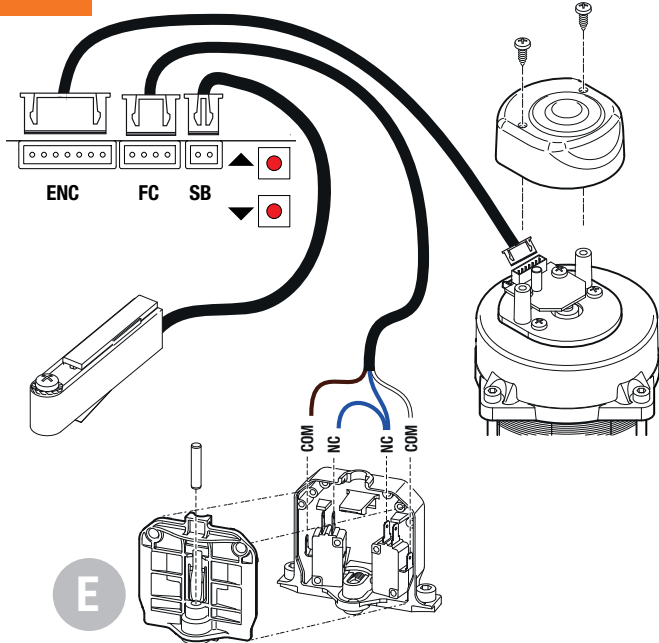

FINECORSA MAGNETICO
MAGNETIC LIMIT
SWITCH

21

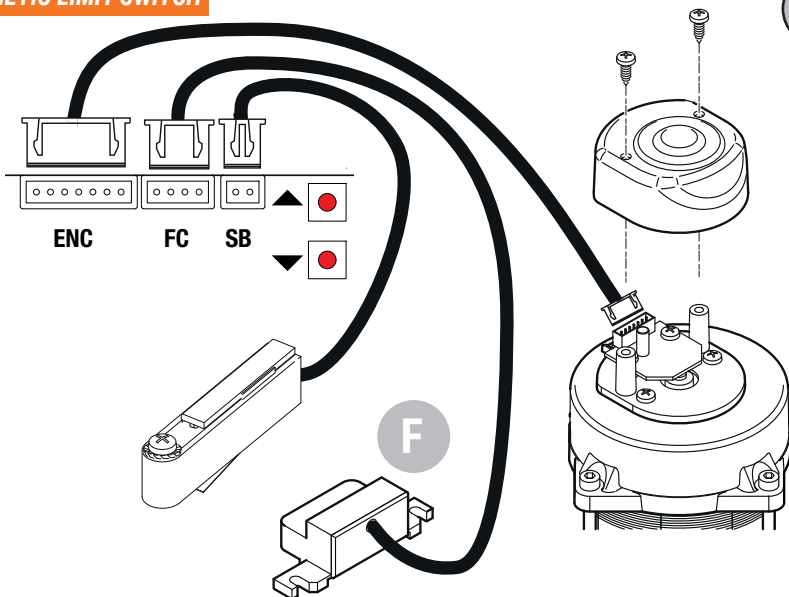

COLLEGAMENTO DI RELAY ESTERNO ALL' USCITA SC
CONNECTION OF EXTERNAL RELAY TO SC OUTPUT

22

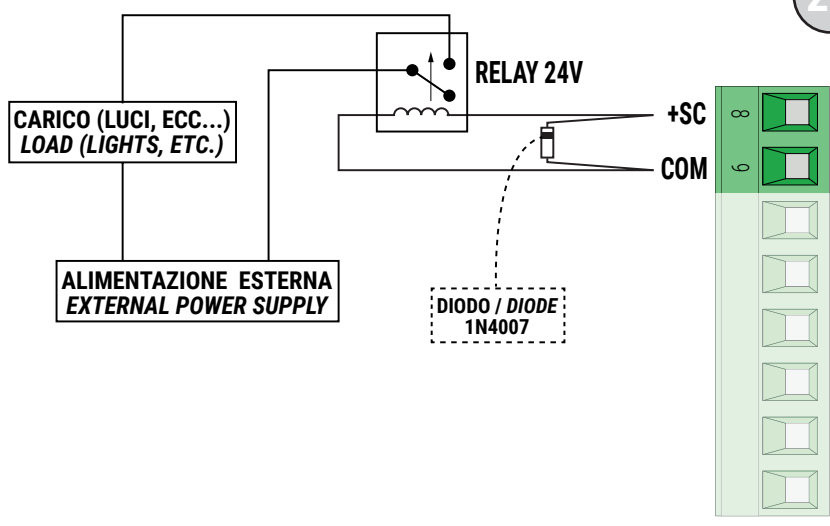

WARNING! This manual is intended for qualified personnel only; carefully read the general warnings supplied with this manual.









WARNING! the H93/RX2LP/I radio receiver is fully compatible with the H93/RX20/I - H93/RX22A/I- H93/RX2RC/I radio receivers, integrating either fixed code or "rolling code" (configurable) decoding operation.

For more information about LOW POWER mode please refer to the B70/MODLP manual and chapter 9.4 Stand By Mode.

For further information on MASTER/SLAVE mode, refer to the MASTER/SLAVE manual, which can be downloaded from the website www.rogertechnology.it in the DOCUMENTATION --> CONTROL UNITS section.

1 Symbols

The symbols and their meaning in the manual or on the product label are indicated below.

	Generic danger. Important safety information. Indicates operations and situations in which the personnel involved must pay close attention.
	Dangerous voltage risk. Indicates operations and situations in which the personnel involved must pay close attention to dangerous voltages.
	Useful information. Indicates useful information for the installation.
	Refer to the Installation and use instructions. Indicates the obligation to refer to the manual or original document, which must be available for future use and must not be damaged in any way.
	Protective earth connection point.
	Indicates the admissible temperature range.
	Alternating current (AC)
	Direct current (DC)
	Symbol for the product disposal according to the WEEE directive.

2 Product description

The **B70/1DC** controller is a unit for the SENSORED control, with a high resolution encoder, of a ROGER brushless motor for automated sliding gates.

 **Ensure that the parameter $P1$ is set correctly. If this parameter is not set correctly, the automation system may not function properly.**

Using the B70/MODLP device connected via 3-wire cabling to the H93/RX2LP/I receiver, the control unit monitors the operating status by entering the "low power" mode after a preset time of inactivity.
ROGER TECHNOLOGY cannot be held responsible for any damage or injury due to improper use or any use other than the intended usage indicated in this manual.

We recommend using only ROGER TECHNOLOGY accessories and control and safety devices. Specifically, we recommend installing **F4ES** or **F4S** series photocells.



 For further information, refer to the installation manual of the **BH30** or **BM30** automation system.

3 Updates of version P3.00

1. Added management of the 'low power' mode, handled by the new parameter L ; this mode requires the use of the H93/RX2LP/I receiver connected to the B70/MODLP
2. Added parameter $L D$ to enable/disable B-CONNECT
3. Added parameter $B D$ to configure the type of limit switch used
4. Added new display messages 'StBY', 'Act i' and 'noLP' relating to low-power operating situations
5. Added parameter $R D$ to enable MASTER/SLAVE mode management for opposing automations

6. Added par.89 to select the target of the parameter setting operations made with B-CONNECT inserted on MASTER control unit (89=00: MASTER target; 89=01: SLAVE target)
7. Added new alarms inherent to MASTER/SLAVE management (COM1...COM4)
8. Added new INFO values inherent to MASTER/SLAVE operation monitoring
9. Added parameter 8B to enable a cyclic activation timer (test mode)
10. Improved management of the persistent AP command
11. Improved management of the reclosing function on photocell intervention (par. 55)
12. Changed the factory value of par.85 to 03
13. Renamed parameter 90 to 'F#'

4 Technical characteristics of product

	BH30/603 BH33/604	BH30/803 BH30/804	BH30/503/HS BH30/504/HS BH30/603/HS BH30/604/HS	BM30/400	BM30/300/HS	BH30/804/R
MAINS POWER VOLTAGE	230 V~ ± 10% 50/60 Hz (B70/1DC/115 : 115 V~ ± 10% 50/60 Hz)					
STAND-BY CONSUMPTION	≤0.5 W					
CONSUMPTION WAITING FOR COMMANDS WITH STAND-BY NOT ACTIVE	4.8 W (*)					
MAXIMUM MAINS POWER ABSORPTION	130 W	140 W	140 W	120 W	125 W	140 W
INRUSH POWER	300 W	450 W	350 W	280 W	320 W	330 W
FUSES	F1 = 15A (ATO257) motor power circuit protection F2 = 2A (ATO257) accessories power supply protection F3 = T2A (5x20 mm) primary transformer protection					
CONNECTABLE MOTORS	1					
MOTOR POWER SUPPLY	24 V~, with self-protected inverter					
MOTOR TYPE	sinusoidal drive brushless (ROGER BRUSHLESS)					
MOTOR CONTROL TYPE	sensored field oriented control (FOC)					
RATED MOTOR POWER	45 W	75 W	120 W	45 W	100 W	110 W
MAXIMUM MOTOR POWER	125 W	200 W	350 W	110 W	320 W	330 W
MAXIMUM POWER, FLASHING LIGHT	13 W (24V $\overleftrightarrow{---}$)	25 W (24V $\overleftrightarrow{---}$)		13 W (24V $\overleftrightarrow{---}$)	25 W (24V $\overleftrightarrow{---}$)	
FLASHING LIGHT DUTY CYCLE	50%					
COURTESY LIGHT POWER	100 W 230 V~ - 40 W 24 V~/ $\overleftrightarrow{---}$ (potential free contact)					
GATE OPEN LIGHT POWER	3 W (24 V $\overleftrightarrow{---}$)					
MAXIMUM ACCESSORY CURRENT ABSORPTION	7 W (24V $\overleftrightarrow{---}$)	10 W (24V $\overleftrightarrow{---}$)		7 W (24V $\overleftrightarrow{---}$)	10 W (24V $\overleftrightarrow{---}$)	
OPERATING TEMPERATURE	 -20°C  +55°C					
PRODUCT DIMENSIONS	dimensions in mm 200x90x45 weight: 0,244 kg					



(1) BH30/500/HS/115 - BH30/600/115 - BH30/600/HS/115 - BH30/800/115 - BH30/804/R/115 - BM30/300/HS/115

(*) indicative consumption in the absence of connected accessories, with plug-in receiver engaged, in the absence of electrical braking applied to the motors (where applicable)

 The total of the absorption values of all the accessories connected must not exceed the maximum power values shown in the table. The values are guaranteed with original ROGER TECHNOLOGY accessories ONLY. The use of non-original accessories may lead to malfunctioning. ROGER TECHNOLOGY declines all responsibility for incorrect or non-conforming installations.
All the connections are protected by fuses (refer to the table). The courtesy light requires an external fuse.

5 Description of connections

To access the control connection terminal board, remove the motor cover as shown in figure 1:

- remove the two screws **A** and lift the cover (detail **B**);
- **BH30**: push the cover in from the side, then lift it up (detail **B**).

See figure 2 if the battery charger **B71/BC (BH30 Series only)** is installed:

- remove the two screws **A**;
- push the cover in from the side, then lift it up (detail **B**).
- turn the cover around by 180° (detail **C**) and set it down in front of the automation system. **Warning!** Lift the cover slowly and carefully to prevent damaging the wires.

Figure 3-4-5-6-7-8 shows connection diagrams for connecting mains voltage to the motor control unit (**B70/1DC**).

5.1 Typical installation

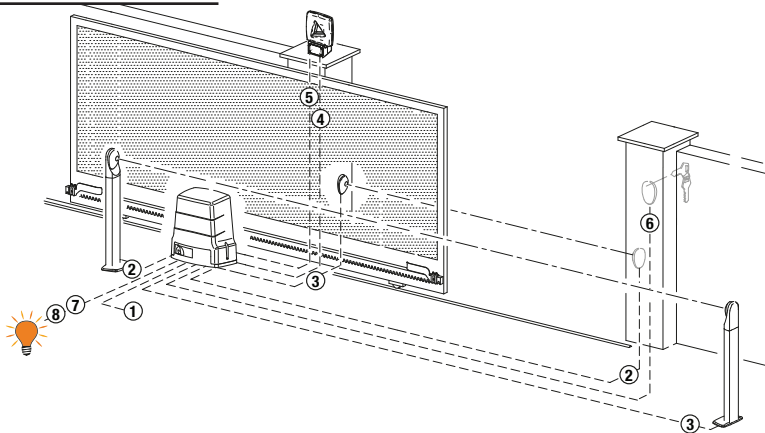

It is the installer's responsibility to verify the adequacy of the cables in relation to the devices used in the installation and their technical characteristics.

		Recommended cable
1	Power supply	H07RN-F 3x1,5 mm ² double insulated cable
2	Photocell - Receiver F4ES/F4S	Cable 5x0,5 mm ² (max 20 m)
3	Photocell - Transmitter F4ES/F4S	Cable 3x0,5 mm ² (max 20 m)
4	LED Flashing light FIFTHY/24	Cable 2x1 mm ² (max 10 m)
5	Antenna	Cable 50 Ohm RG58 (max 10 m)
6	Key selector R85/60	Cable 3x0,5 mm ² (max 20 m)
	Key pad H85/TTD - H85/TDS (connecting to H85/DEC - H85/DEC2)	Cable 2x0,5 mm ² (max 30 m)
	H85/DEC - H85/DEC2 (connecting to control unit)	Cable 4x0,5 mm ² (max 20 m) The number of conductors increases when using more than one output contact on H85/DEC - H85/DEC2
7	Gate open indicator	Cable 2x0,5 mm ² (max 20 m)
8	Courtesy light (potential free contact)	Cable 2x1 mm ² (max 20 m)



SUGGESTIONS: with existing installations, we recommend checking the cross section of the cables and that the cables themselves are in good condition.

5.2 Electrical connections

A switch or an omnipolar cut-off switch with a contact opening of at least 3 mm must be installed on the mains power line; put the cut-off switch in OFF position and disconnect any buffer batteries before performing any cleaning or maintenance operations.

Ensure that an adequate residual current circuit breaker with a 0.03 A threshold and a suitable overcurrent cut-out are installed upstream the electrical installation in accordance with best practices and in compliance with applicable legislation.

For power supply, use a H07RN-F 3G1.5 type electric cable and connect it to the terminals L (brown), N (blue),  (yellow/green), located inside the automation system.

Strip the insulation from the ends of the power cable wires which will be connected to the terminal (see ref. D, fig. 3-7), and secure the cable with the cable retainer.

Measure the voltage on the primary mains power connection with a tester.

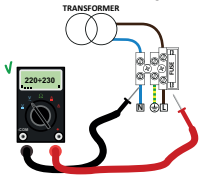

For the Brushless automation system to function correctly, the mains power voltage must be:

- 230V~ ±10% for the B70/1DC control unit.
- 115V~ ±10% for the B70/1DC/115 control unit.

If the detected value does not comply with the above specified values or is not stable, the automation system may NOT operate efficiently.

i Connections to the electrical distribution network and to any other low-voltage conductors in the external section to the electrical panel must be on an independent path and separate from the connections to the command and safety devices (SELV = Safety Extra Low Voltage).

Make sure that the mains power conductors and the accessory wires (24 V) are separated.

The cables must be double insulated, strip them near the relevant connection terminals and lock them with clamps (not supplied).

	DESCRIPTION
	Mains power supply 230 V~ ±10%, 50/60 Hz (115 V~ ±10%, 50/60 Hz) fuse 5x20 T2A connection.
<p>POWER IN</p>	<p>Power feed input from transformer (or from B71/BC battery charger - only BH30 series - if used, fig. 2).</p> <p>N.B.: Ready wired in factory by ROGER TECHNOLOGY.</p> <p>WARNING! With the board powered the battery connected, pay maximum attention to the polarity (see fig. 2).</p>
<p>X-Y-Z</p>	<p>Connection to ROGER brushless motor.</p> <p>Connecting B72/BRAKE / B72/BRCL controller for BH30 High Speed (fig. 5) and BM30 High Speed versions (fig. 8).</p> <p>N.B.: Ready wired in factory by ROGER TECHNOLOGY.</p> <p>Warning! If the motor wires become disconnected from the terminal board, after reconnecting correctly, the gate travel must be acquired again as described in chapter 10.</p>

6 Commands and Accessories











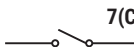

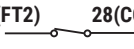
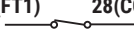
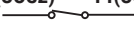
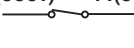
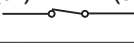

If not installed, safety devices with NC contacts must be jumpered at the COM terminals, or disabled by modifying the parameters *50*, *51*, *53*, *54*, *73* and *74*.

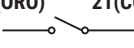
KEY:

N.A. (Normally Open).

N.C. (Normally Closed).

CONTACT	DESCRIPTION
6  7(COR)	Output (potential free contact) for connecting courtesy light. 230 V~ 100 W - 24 V~/--- 40 W (fig. 9). NOTE: Provide a protective fuse.
6  7(COR)	Error alert contact only, for: <ul style="list-style-type: none"> • Unlocked gate / battery supply error (low battery); • Gate completely open / gate completely closed (fig. 10). The COR output operating mode is managed by parameter <i>20</i> . The voltage level of the battery can be set via parameter <i>85</i> .
8(+SC)  9(COM)	Connection for gate open indicator lamp. 24V--- 3 W. The function of the indicator lamp is determined by parameter <i>AB</i> .
8(+SC)  9(COM)	Photocell test connection and/or battery saving (fig. 13-14-15-16) The power feed for the photocell transmitters (TX) may be connected to this. Set the parameter <i>AB02</i> to enable the test function. Each time a command is received, the control unit switches the photocells off and on to check that the contact changes state correctly. Power feeds for all external devices may be connected to reduce battery consumption (if batteries are used). Set <i>AB03</i> or <i>AB04</i> . WARNING! If contact 8-SC is used for the photocell test function or battery saving function, a gate open indicator lamp cannot be connected.
10(FT2)  28(COM)	Input (NC) for connecting photocells FT2 (fig. 11-12-13-14-15-16). The photocells FT2 are configured by default with the following settings: <ul style="list-style-type: none"> - <i>5300</i>. Photocell FT2 disabled when gate is opening. - <i>5400</i>. Photocell FT2 disabled when gate is closing. - <i>5501</i>. The gate opens when an open command is received if photocell FT2 is obstructed. If the photocells are not installed, jumper the terminals 28(COM) - 10(FT2) or set the parameters <i>5300</i> and <i>5400</i> . WARNING! Use F4ES or F4S series photocells.
11(FT1)  28(COM)	Input (NC) for connecting photocells FT1 (fig. 11-12-13-14-15-16). The photocells FT1 are configured by default with the following settings: <ul style="list-style-type: none"> - <i>5000</i>. Photocell triggers only during gate closure. Photocell is ignored during gate opening. - <i>5102</i>. Movement is reversed if the photocell is triggered during gate closure. - <i>5201</i>. The gate opens when an open command is received if photocell FT1 is obstructed. If the photocells are not installed, jumper the terminals 28(COM) - 11(FT1) or set the parameters <i>5000</i> and <i>5102</i> . WARNING! Use F4ES or F4S series photocells.
12(COS2)  14(COM)	Input (NC or 8 kOhm) for connecting sensing edge COS2 (fig. 9). The sensing edge is configured by default with the following settings: <ul style="list-style-type: none"> - <i>7400</i>. The sensing edge COS2 (NC contact) is disabled. If the sensing edge is not installed, jumper the terminals 12(COS2) - 14(COM) or set the parameter <i>7400</i> .
13(COS1)  14(COM)	Input (NC or 8 kOhm) for connecting sensing edge COS1 (fig. 9). The sensing edge is configured by default with the following settings: <ul style="list-style-type: none"> - <i>7300</i>. The sensing edge COS1 (NC contact) is disabled. If the sensing edge is not installed, jumper the terminals 13(COS1) - 14(COM) or set the parameter <i>7300</i> .
15(ST)  14(COM)	STOP command input (NC). The current manoeuvre is arrested if the safety contact opens. N.B.: the controller is supplied with this contact already jumpered by ROGER TECHNOLOGY.
20  19(ANT)	Antenna connector for slot-in radio receiver board. Use RG58 if an external antenna is used, maximum recommended length: 10 m. N.B.: do not make joints in cable.
22(ORO)  21(COM)	Clock timer contact input (N.O.). When the clock function is active, the gate opens and remains open. At the end of the programmed time set with the external device (clock), the gate closes. The function of this command is determined by parameter <i>BD</i> .

CONTACT		DESCRIPTION
23(AP)	 21(COM)	Open control signal input (N.O.). IMPORTANT: persistent activation of the opening command prevents automatic reclosure; the automatic reclosure time count is resumed when the opening command is released.
24(CH)	 21(COM)	Close command input (N.O.).
25(PP)	 21(COM)	Step by step mode command input (N.O.). The function of the control is determined by parameter <i>PH</i> .
26(PED)	 21(COM)	Partial open control signal input (N.O.). Set by default to 50% of completely open position.
27(+24V)	28(COM)	Power feed for external devices. See technical characteristics. Connecting B72/BRAKE - B72/BRCL power unit for BH30 High Speed (fig. 5), BH30 Reversible (fig. 6) and BM30 High Speed versions (fig. 8)
29(LAM)	 28(COM)	Connection for flashing light (24V $\overline{\text{---}}$ - duty cycle 50%). The settings for the pre-manoeuve flashing warning signal may be selected with parameter <i>PS</i> , while the flashing mode is set with parameter <i>7B</i> .
ENC		Connector for connecting to encoder installed on motor. WARNING! Always disconnect from electrical power before disconnecting or connecting the encoder cable. In case of encoder replacement, repeat the acquisition procedure. N.B.: Ready wired in factory by ROGER TECHNOLOGY.
FC		Connector (N.C. contacts) for connecting mechanical limit switch (see figure 20 - detail E) or magnetic limit switch (see figure 21 - detail F). The gate stops when the limit switch is activated. IMPORTANT: repeat the travel acquisition procedure after each adjustment to the limit switches. N.B.: Ready wired in factory by ROGER TECHNOLOGY.
SB		Connector (N.C.) for connecting release contact. If the motor release handle is opened, the gate stops and no command signals are accepted. Once the release handle is closed again, if the gate is in an intermediate position, the controller unit initiates the position recovery procedure (see chapter 19). N.B.: Ready wired in factory by ROGER TECHNOLOGY.
RECEIVER CARD H93/RX2LP/I		Connector for plug-in radio receiver board. The control unit has two radio remote control functions by default: - PR1 - step mode command (modifiable with parameter <i>7E</i>). - PR2 - partial opening command (modifiable with parameter <i>77</i>). The programming buttons PR1 and PR2 are also accessible with the cover closed (see fig. 17). The receiver is connected to the B70/MODLP module by means of 3-wire cabling (the cabling is factory-made by ROGER TECHNOLOGY) and is indispensable for managing the "low power" mode. ATTENTION! H93/RX2LP/I must not be replaced with other ROGER plug-in receiver models.
WIFI		Connector for B74/BCONNECT WiFi IP device. This IP device allows, using any internet browser, the complete management of the control panel both in proximity (point-to-point connection) and via cloud (remote connection).
ONLY BH30 Series	BATTERY CHARGER B71/BC	The use of the battery charger and buffer batteries is only possible by disabling the "low power" mode (L \neq 00). In the event of a mains power loss, the controller unit is powered by the batteries. When battery power is used, BATT is shown on the display and the flashing light flashes briefly at intervals until mains power is restored or until the battery voltage drops below the minimum permissible limit. In this case, BATT (Battery Low) is shown on the display and the controller unit accepts no commands. WARNING! the batteries must always be connected to the electronic controller unit in order to charge. Periodically (at least every 6 months), check that the battery is in good working order.
	2x12V $\overline{\text{---}}$ 1,2 Ah. or 2x12V $\overline{\text{---}}$ 4,5 Ah	Two battery kits are available: • Two 12V $\overline{\text{---}}$ 1,2 Ah batteries installed in the automation system itself. • Two 12V $\overline{\text{---}}$ 4,5 Ah batteries installed in an external case. For more information, refer to the installation manual for the B71/BC battery charger. WARNING: it is recommended to use AGM type batteries.

CONTACT

DESCRIPTION

BATTERY CHARGER

B71/BC
2x12V⁻⁻⁻
1,2 Ah.

To install the battery charger and the 12V⁻⁻⁻, 1,2 Ah batteries:

- Remove the upper cover **G**.
- Remove the cover **H**.
- Install the **B71/BC** battery charger board in the relative seat.
- Disconnect the wires from the transformer and from the **POWER IN** terminal of the controller unit, and connect them to terminal **I** of the battery charger.
- Connect the red-black wires of cable **L** included with the battery to the **POWER IN** terminal **M** of the controller unit.
- Close the cover **H** and fasten with the screws.
- Fit the 12V⁻⁻⁻ 1.2 Ah batteries in the relative compartment, ensuring that the polarity is correct.
- Close the upper cover **G**.

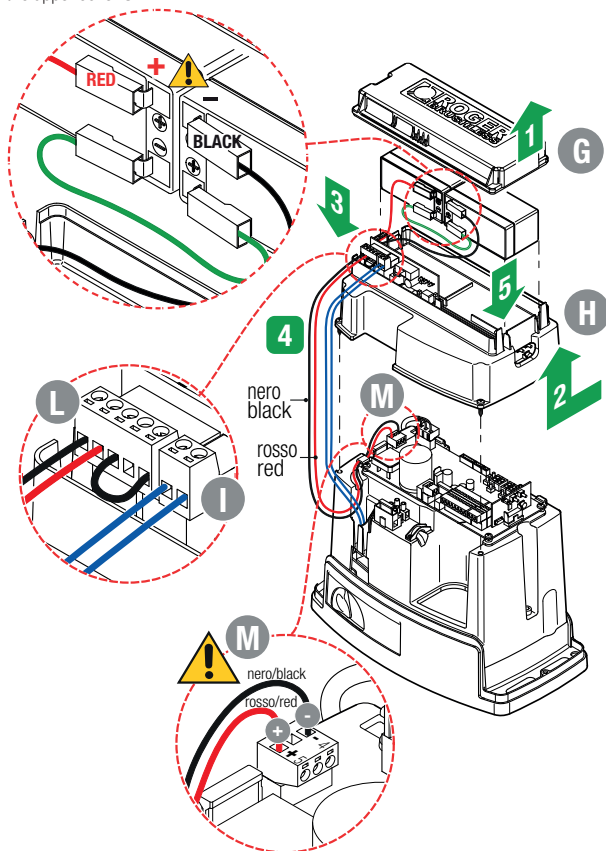

To reduce battery consumption, the positive power feed wire of the photocell transmitters may be connected to terminal **SC** (see fig. 13-14-15-16). Set **AB03** or **AB04**. In this configuration, the controller unit disconnects power from the accessory devices when the gate is completely open or completely closed.

7 Function buttons and display

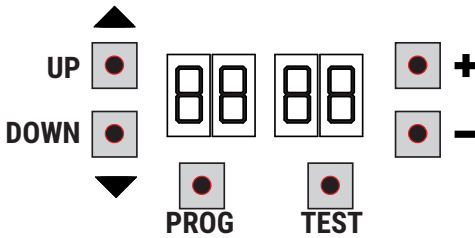

BUTTON	DESCRIPTION
UP ▲	Next parameter
DOWN ▼	Previous parameter
+	Increase value of parameter by 1
-	Decrease value of parameter by 1
PROG	Travel acquisition
TEST	Activate TEST mode

- Press the UP ▲ and/or DOWN ▼ buttons to view the parameter you intend to modify.
- Use the + and - buttons to modify the value of the parameter. The value starts to flash.
- Press and hold the + or - button to scroll quickly through values, to modify the parameter more quickly.
- To save the new value, wait a few seconds or move onto another parameter with the UP ▲ or DOWN ▼ button. The display flashes rapidly to indicate that the new value has been saved.
- Parameters can only be modified while the motor is not running. Parameters can be viewed at any time.

8 Switching on or commissioning

Power the control unit.
The firmware version of the control unit is displayed briefly.
Version installed P3.00.

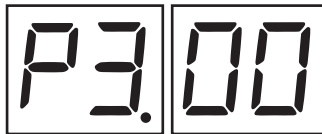

Immediately afterwards:

- For a control unit mounted on an automation (or supplied with an automation): the display shows the control and safety status mode (chapter 9)
- For a control unit purchased as a spare part: the display shows "dP&A" and requests initial programming of the stroke (chapter 10)

In both cases, **the execution of stroke programming is mandatory** in order to store on the control unit:

- the parameters required for motor control
- the stroke length

ATTENTION!

Failure to carry out stroke programming can lead to serious malfunctions.

9 Display function modes

9.1 Parameter display mode

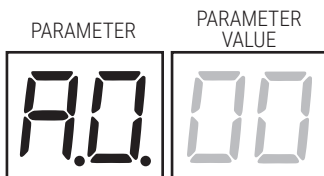

See chapter 12 for detailed descriptions of parameters.

9.2 Command and safety device status display mode

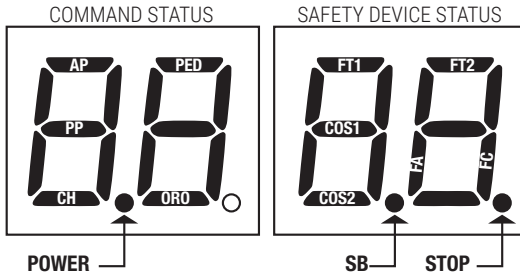

COMMAND STATUS:

The command status indicators on the display are normally OFF.

They ILLUMINATE when a command is received (e.g.: when a step mode command is received, the segment PP illuminates).

SEGMENT	COMMAND
AP	open
PP	step by step mode
CH	close
PEd	partial opening
OR	clock

SAFETY DEVICE STATUS:

The safety device status indicators on the display are normally ON.

If an indicator is OFF, the relative device is in alarm state or is not connected.

The an indicator is FLASHING, the relative device has been disabled with a specific parameter.

SEGMENT	SAFETY
FT1	photocell
FT2	photocell
COS1	sensing edge
COS2	sensing edge
FA	gate open limit switch
FC	gate closed limit switch
Sb	release handle open

9.3 TEST mode

The TEST mode is used to test activation of the commands and safety devices with visual confirmation. To activate the mode, press the TEST button with the automatic door system at rest. If the gate is moving, pressing TEST stops the gate. Pressing the button again enables TEST mode. If the flashing light and the gate open indicator lamp illuminate for one second each time a control is used or a safety device is activated.

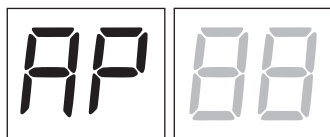

The command signal status is shown on the left hand side of the display for 5 seconds, ONLY when the respective command signal is active (AP, CH, PP, PE, OR). For example, if the gate open command is activated, the letters AP appear on the display.

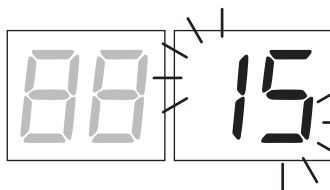

The status of the safety devices/inputs is shown on the right hand side of the display. The number of the terminal relative to the safety device in alarm state flashes.

When the gate is completely open or completely closed, FR or FC is shown on the display to indicate that the gate has reached the gate open limit switch FR or gate closed limit switch FC.

Example: STOP contact in alarm state

00	No safety device in alarm state and no limit switch activated.
5b (Sb)	Release handle or lock open.
15	STOP contact (N.C.) open. If there is no STOP switch, jumper the contact.
13	Sensing edge contact COS1 (N.C.) is open. Check connection. If sensing edge is not installed, disable with 7300.
12	Sensing edge contact COS2 (N.C.) is open. Check connection. If sensing edge is not installed, disable with 7400.
11	Photocell contact FT1 (N.C.) is open. Check connection. If photocell is not installed, disable with 5000.
10	Photocell contact FT2 (N.C.) is open. Check connection. If photocell is not installed, disable with 5300.
FE	Both limit switches in error state. Check connections and settings of limit switches.
FR	If gate is open, gate open limit switch is detected.
FC	If gate is closed, gate closed limit switch is detected.
nC	If par.A0 is not 00 (RS485 communication enabled), this indicates no communication.

NOTA: If one or more contacts are open, the gate will not open or close. This does not apply for the limit switch signal state, however, which is shown on the display but does not prevent normal operation of the gate.

If more than one safety device is in alarm state, once the problem relative to the first device is resolved, the alarm for the next device is displayed. Any further alarm states are also displayed with the same logic.

Press the TEST button again to exit test mode.

After 10 seconds with no user input, the display returns to command and safety device state display mode.

If you are viewing the MASTER control unit (par.A0=0 i), the safety number activated on the SLAVE control unit appears with two decimal points lit (example: STOP active on MASTER displays '15', STOP active on SLAVE displays '1.5'). Similarly, when consulting the SLAVE control panel display (par.A0=02 or 03), the security number activated on the MASTER will have two decimal points lit (indicating 'remote security activation', i.e. connected to the twin control panel).

For further information on MASTER/SLAVE mode, refer to the MASTER/SLAVE manual, which can be downloaded from the website www.rogertechnology.it in the DOCUMENTATION --> CONTROL UNITS section.

9.4 Standby mode

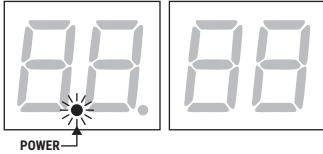

There are two possible stand-by situations:

1. The one that simply turns off the display, leaving only the LED POWER flashing: this is activated after 30 min of inactivity and is only possible if low power management (L 1 00) is not enabled

2. The one that brings the power consumption of the control unit to a value ≤ 0.5 W, by default it is set to activate after 20 minutes of inactivity (L 1 04) but with a parameter value of 0 1, 02, 03 it can be set to 5-10-15 minutes of inactivity.

In this operating situation, the transformer is not powered, and only the logic section of the control unit, powered by the B70/MODLP module, remains in operation.

The 24V $\overline{\text{---}}$ output of the control unit is therefore not powered, with the following consequences:

- it is not possible to use an external receiver, unless this is powered by a source external to the control unit
- it is not possible to use certain command modes based on the crossing of the photocells, as the photocells are also not powered; reference to the settings of parameters 52 and 55 (to command opening) and 56 (to have reclosing after 6 seconds)

Other consequences:

- it is not possible to have backup batteries, as in stand-by they would not receive a charge (not even the maintenance charge) and above all, lacking the alternating transformer voltage (due to its shutdown operated by B70/MODLP) would activate the power supply from the battery ("bAtt" on the display), discharging it unnecessarily. To use the batteries it is compulsory to disable the "low power" mode (L 1 00)
- it is not possible to use B-CONNECT, because in stand-by the control unit does not communicate with it therefore it does not provide information nor does it allow the control unit to be controlled. To use B-CONNECT you must disable the "low power" mode (L 1 00).

The "low power" stand-by time countdown is managed as follows:

- resets when a command is received and as long as the drive is in motion
- resets if the drive is paused for reclosing (parameters R2 and 2 1), as this is still an active phase of the drive
- resets if the guaranteed reclosing countdown is running (par.02)
- resets if the COR output timing is in operation
- resets when one of the keys around the display is activated

Only at the end of the situations listed above does the countdown begin, which at the end of the time (selected in parameter L 1) leads to the "low power" stand-by phase.

The display shows "5 5 5" and after 1.5" turns off the display and deactivates the SC, LAM and COR outputs.

To activate stand-by without having to wait and be able to test the "low power" operation:

simultaneously activate the 4 buttons: UP ▲, DOWN ▼, + and - for about a second and a half: you will hear the relay switch inside the B70/MODLP and the display will show "5 5 5".

If for some reason the B70/MODLP fails to disconnect power to the transformer, "noLP" will appear on the central unit display after approximately 8 seconds, indicating that the "low power" has not been activated.

Exit from the stand-by mode occurs in one of the following ways:

- upon activation of a terminal board command (AP, CH, PP, PE, OR)
- upon activation of a radio command
- upon activation of one of the buttons PROG, TEST

ATTENTION! The OR command cannot wake up the control unit once it has entered standby mode.

Its use to activate closure at predetermined times (when the control unit would definitely have entered standby mode) is only possible by disabling low-power mode (L 1 00).

Waking up from stand-by is indicated by the display message "R 1 1", which signals the reactivation of the control unit. **ATTENTION!** Reactivation involves re-powering the transformer, i.e. the return of the 24 V power supply to the control unit: the reaction to a command is slightly delayed as one has to wait for a time to stabilise the operation of the photocells and to be able to assess whether they are in alarm or not.



10 Travel acquisition

i For the system to function correctly, the barrier travel must be acquired by the controller.

10.1 Before starting

1. Select the automation system model installed with the parameter *A 1*.

KEY:  **HIGH SPEED Motors**  **REVERSIBLE Motor**

SELECTION	MODEL	MOTOR TYPE	CONFIGURATION
<i>A 1 01</i>	BH30/603 BH30/604	/	600kg IRREVERSIBLE
<i>A 1 02</i>	BH30/803 BH30/804	/	1000kg IRREVERSIBLE
<i>A 1 03</i>	BH30/503/HS BH30/504/HS BH30/603/HS BH30/604/HS		600kg IRREVERSIBLE HIGH SPEED see chapter 13 "Special Parameters for High Speed Motor"
<i>A 1 04</i>	BM30/400	/	500kg IRREVERSIBLE
<i>A 1 05</i>	BM30/300/HS		400kg IRREVERSIBLE HIGH SPEED see chapter 13 "Special Parameters for High Speed Motor"
<i>A 1 06</i>	BH30/804/R		800kg REVERSIBLE see chapter 14 "Special Parameters for Reversible Motor"

2. Select the position of the motor relative to the gate with the parameter *7 1*. The default setting for this parameter is with the motor installed on the right hand side of the gate (seen from interior side).

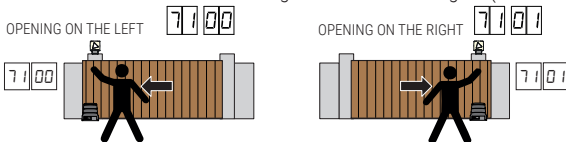

3. Adjust the (mechanical or magnetic) limit switches so that, once triggered, the gate stops slightly before it reaches the mechanical stop.

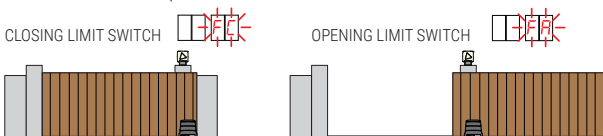

4. Check that the operator present function is not enabled (*A7 00*).

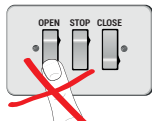

5. Move the gate into the closed position.

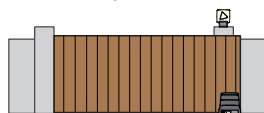

6. Press **TEST** (see TEST mode in chapter 9) and check the command signal and safety device states. If any safety devices are not installed, jumper the relative contact or disable the device from the relative parameter (*50, 5 1, 53, 54, 73* and *74*).

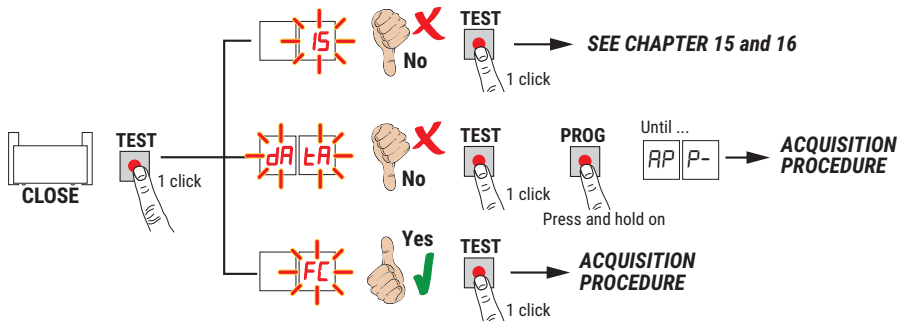

10.2 Acquisition procedure

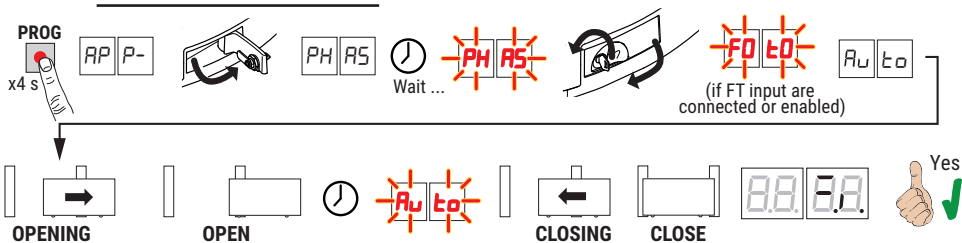

- Press and hold **PROG** for 4 seconds. *AP P-* is shown on the display.
 - Open the release handle. The message *PH AS* appears on the display after a few seconds. The controller unit launches a calibration procedure. The operating parameters of the motor are determined during calibration.
 - If the motor calibration procedure is successful, the message *PH AS* flashes on the display.
 - Close the release handle. The acquisition procedure now starts.
 - *FO EO* is shown on the display (only if parameters *S0*, *S 1*, *S3*, *S4* are not disabled). Keep away from the photocell beam within 5 s, to prevent interrupting the procedure.
 - *Au EO* is shown on the display and the gate starts opening at low speed.
 - The gate stops briefly when it reaches the gate open limit switch. *Au EO* flashes on the display.
 - The gate closes until it reaches the gate closed limit switch.
- If the acquisition procedure is completed successfully, the display enters the command and safety device state display mode.



If the following error messages are shown on the display, repeat the acquisition procedure:

- *no PH*: calibration procedure failed.
- *AP PE*: acquisition error. Press the **TEST** button to clear the error, and check the safety device in alarm state.
- *AP PL*: travel length error. Press the **TEST** button to clear the error, and check that gate is completely closed.

ATTENTION: if the acquisition procedure was successful **BUT** the space between the leaf (stopped at the limit switch) and the mechanical stop is not as desired, move the limit switch and **REPEAT THE ACQUISITION PROCEDURE**. Ensure that **AT LEAST** 3 centimetres remain between the leaf stop and the mechanical stop.

i For more information, see chapter 16 "Alarms and faults".

11 Parameter's index

PARAM.	FACTORY DEFAULT	DESCRIPTION	PAGE
R0	00	Enable RS485 serial communication (MASTER-SLAVE)	74
R1	see chap. 10	Selecting automation system model	74
R2	00	Automatic closure after pause time (from gate completely open)	74
R3	00	Automatic gate closing after mains power outage	74
R4	00	Selecting step mode control function (PP)	74
R5	00	Pre-flashing	75
R6	00	Condominium function for partial open command (PED)	75
R7	00	Enabling operator present function	75
R8	00	Gate open indicator / photocell test function and "battery saving"	75
11	04	Setting deceleration during opening (and closing for BH30/603 - BH30/604 - BH30/803 - BH30/804 - BM30/400)	75
12 	04	Setting deceleration during closing (High Speed - Reversible Series only)	75
13	05	Setting gate open limit switch constant speed approach distance	75
14	05	Setting gate closed limit switch constant speed approach distance	75
15	50	Partial opening adjustment (%)	75
16	00	Adjusting automatic closing time after partial opening	75
20	00	COR output operating mode	76
21	30	Setting automatic closing time	76
22	00	Enabling of management for opening with automatic re-closure exclusion	76
27	03	Setting reverse time after activation of sensing edge or obstacle detection (crush prevention)	76
30	05	Setting motor torque	76
31	15	Setting obstacle impact force sensitivity	76
33	04	Setting start acceleration during opening (and closing for BH30/603 - BH30/604 - BH30/803 - BH30/804 - BM30/400)	77
34 	04	Setting start acceleration during closing (High Speed - Reversible Series only)	77
36	00	Enabling maximum torque boost at start of manoeuvre	77
37	00	Setting motor torque during position recovery	77
40	05	Setting opening speed (%) (and closing for BH30/603 - BH30/604 - BH30/803 - BH30/804 - BM30/400)	77
41 	05	Setting closing speed (%) (High Speed - Reversible Series only)	77
42	03	Setting end of manoeuvre constant approach speed	77
49	01	Setting number of automatic closure attempts after activation of sensing edge or obstacle detection (crush protection)	77
50	00	Setting photocell mode during gate opening (FT1)	77
51	02	Setting photocell mode during gate closing (FT1)	78
52	01	Photocell (FT1) mode with gate closed	78
53	00	Setting photocell mode during gate opening (FT2)	78
54	00	Setting photocell mode during gate closing (FT2)	78
55	01	Photocell (FT2) mode with gate closed	78

PARAM.	FACTORY DEFAULT	DESCRIPTION	PAGE
56	00	Enable close command 6 s after activation of photocell (FT1-FT2)	78
60	01	Limit switch type selection	78
65	05	Setting motor stop distance	78
71	01	Selecting installation position of motor relative to gate (seen from interior side)	79
73	00	Configuring sensing edge COS1	79
74	00	Configuring sensing edge COS2	79
76	00	Configuring radio channel 1 (PR1)	79
77	01	Configuring radio channel 2 (PR2)	79
78	00	Configuring flashing light frequency	79
79	60	Selecting courtesy light mode	79
80	00	Clock contact configuration	80
81	00	Enable safeguarded gate closure/opening	80
82	03	Setting safeguarded closure/opening activation time	80
85	03	Selection of the battery operation management	80
86	00	Selection of the battery operation limitations	80
87	00	Selection of the battery type and consumption reduction	81
88	00	Cyclical activation (test mode)	81
89	00	Enabling parameter management of the SLAVE control unit using B74/BCONNECT inserted on the MASTER control unit	81
L0	00	Enabling serial communication	81
L1	04	"Low power stand-by" mode configuration	81
FR	00	Restoring factory default values	81
n0	01	HW version	82
n1	23	Year of manufacture	82
n2	45	Week of manufacture	82
n3	67	Serial number	82
n4	89		82
n5	01		82
n6	23		82
o7	01	View manoeuvre counter	82
o0	23		82
o1	45		82
h0	01	View manoeuvre hour counter	82
h1	23		82
d0	01	View control unit days on counter	82
d1	23		82
P1	00	Password	82
P2	00		82
P3	00		82
P4	00		82
CP	00	Changing password	82

12 Parameters menu

PARAMETER PARAMETER
VALUE

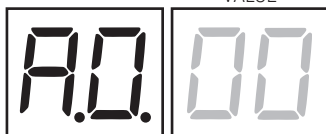

A0 00	Enable RS485 serial communication (MASTER-SLAVE) For further information on MASTER/SLAVE mode, refer to the MASTER/SLAVE manual, which can be downloaded from the website www.rogertechnology.it in the DOCUMENTATION --> CONTROL UNITS section.
00	Standard operation (no MASTER/SLAVE): single automation installation
01	MASTER/SLAVE mode enabled: the control unit acts as MASTER unit
02	MASTER/SLAVE mode enabled: the control unit acts as SLAVE unit, with a copy of the parameters set on the MASTER unit ("mirroring" the parameters) ATTENTION! Setting value 02 on the SLAVE forces the MASTER parameters to be copied to the SLAVE, with the following exceptions: - par. A0 is not changed - par. 50...55 are set to disable the photocells on the SLAVE control unit: this is the case when all photocells are connected to the MASTER control unit. If some photocells are connected to the SLAVE unit instead (to make the installation simpler, e.g. those covering the blind side of the SLAVE automation movement), they must be enabled also on the SLAVE unit (see Chapters 4 and 5) - par. 71 is set to the value opposite to that of the MASTER unit Each subsequent change made to the MASTER parameters is also performed simultaneously on the SLAVE unit (*)
03	MASTER/SLAVE mode enabled: the control unit acts as SLAVE unit, with parameters completely independent of the MASTER unit; therefore, the parameters must be set on the SLAVE unit as well

(*) Some parameters may be edited manually also from the SLAVE control unit. This occurs because the two automations can have different characteristics, and therefore require different adjustments (forces, acceleration, deceleration, speed), or they could/could not be equipped with locally connected safety devices (e.g.: the sensing edge on the SLAVE automation, which is logically connected to the SLAVE control unit for ease of installation).

These parameters are: **11, 12, 20, 30, 31, 33, 34, 40, 41, 42, 50...55, 71, 73, 74**

A101	Selecting automation system model WARNING! If this parameter is not set correctly, the automation system may not function properly. N.B.: in the event of a reset to restore the default parameters, this parameter must be set again manually. Setting values 03, 05, 06 disables "low power" mode, par. L1 is not displayed.	
01	BH30/603 - IRREVERSIBLE motor for gate leaves up to 600 kg BH30/604 - IRREVERSIBLE motor for gate leaves up to 600 kg	
02	BH30/803 - IRREVERSIBLE motor for gate leaves up to 1000 kg BH30/804 - IRREVERSIBLE motor for gate leaves up to 1000 kg	
03	BH30/503/HS - BH30/504/HS - IRREVERSIBLE HIGH SPEED motor for gate leaves up to 600 kg BH30/603/HS - BH30/604/HS - IRREVERSIBLE HIGH SPEED motor for gate leaves up to 600 kg (see chapter 13 "Special parameters for High Speed series")	
04	BM30/400 - IRREVERSIBLE motor for gate leaves up to 500 kg	
05	BM30/300/HS - IRREVERSIBLE HIGH SPEED motor for gate leaves up to 400 kg (see chapter 13 "Special parameters for High Speed series")	
06	BH30/804/R - REVERSIBLE motor for gate leaves up to 800 kg (see chapter 14 "Special parameters for High Speed series")	

A2 00	Automatic closure after pause time (from gate completely open)
00	Disabled.
01-15	From 1 to 15 of gate closure attempts after photocell is triggered. Once the number of attempts set is reached, the gate remains open.
99	The gate tries to close indefinitely.

A3 00	Automatic gate closing after mains power outage
00	Disabled. The gate does not close automatically when mains power is restored.
01	Enabled. If the gate is NOT completely open, when mains power is restored, the gate closes after a 5 second warning signalled with the flashing light (independently of the value set with the parameter A5). The gate closes in "position recovery" mode (see chapter 19).

A4 00	Selecting step mode control function (PP)
00	Open-stop-close-stop-open-stop-close...
01	Condominium function: the gate opens and closes after the set automatic closing time. The automatic closing timer restarts if a new step mode command is received. Step mode commands are ignored while the gate is opening. This allows the gate to open completely and prevents the gate from closing when not required. If automatic closing is disabled (A2 00), the condominium function automatically attempts a closing manoeuvre A2 01.
02	Condominium function: the gate opens and closes after the set automatic closing time. The automatic closing timer does NOT restart if a new step mode command is received. Step mode commands are ignored while the gate is opening. This allows the gate to open completely and prevents the gate from closing when not required. If automatic closing is disabled (A2 00), the condominium function automatically attempts a closing manoeuvre A2 01.
03	Open-close-open-close.
04	Open-close-stop-open.
A5 00	Pre-flashing
00	Disabled. The flashing light is activated during opening and closing manoeuvres.
01-10	Flashing warning signal for 1 to 10 seconds prior to every manoeuvre.
99	5 second flashing warning signal prior to closing manoeuvre.
A6 00	Condominium function for partial open command (PED)
00	Disabled. The gate opens partially in step mode: open-stop-close-stop-open...
01	Enabled. Partial commands are ignored during gate opening.
A7 00	Enabling operator present function
00	Disabled.
01	Enabled. The open (AP) or close (CH) button must be pressed continuously to operate the gate. The gate stops when the button is released.
A8 00	Gate open indicator / photocell test function and "battery saving" NOTE: the signal given by the gate open indicator can only be used if the "low power" mode is disabled (L 100)
00	The indicator is off when the gate is closed, and steadily lit during manoeuvres and when the gate is open.
01	The indicator flashes slowly during opening manoeuvres, and is lit steadily when the gate is completely open. It flashes quickly during closing manoeuvres. If the gate is stopped in an intermediate position, the lamp extinguishes twice every 15 seconds.
02	Set 02 if the output SC is used for the photocell test. See fig. 13-14.
03	Set to 03 if the output SC is used for the "battery saving" function. See fig. 15-16. When the gate is completely open or closed, the controller unit deactivates any accessories connected to terminal SC to reduce battery consumption.
04	Set to 04 if the output SC is used for the "battery saving" function and photocell test function. See fig. 15-16.
11 04	Setting deceleration during opening and closing
12 04	See chapter 13-14 "Special parameters for High Speed and Reversible series"
01-05	01= the gate decelerates near the limit switch ... 05= the gate decelerates long before the limit switch.
13 05	Setting gate open limit switch constant speed approach distance N.B.: the manoeuvre speed is set with parameter 42. After decelerating, the gate completes the distance to the limit switch at constant speed.
14 05	Setting gate closed limit switch constant speed approach distance N.B.: the manoeuvre speed is set with parameter 42. After decelerating, the gate completes the distance to the limit switch at constant speed.
05-40	05= Approximate 15 cm distance; ... 10= Approximate 30 cm distance; ... 40= Approximate 120 cm distance.
15 50	Partial opening adjustment (%) N.B.: This parameter is set to 50% (half of total gate travel) by default.
10-99	From 10% to 99% of total gate travel.

16 10	Adjusting automatic closing time after partial opening The countdown starts when the pedestrian opening is reached, as defined in paragraph 15.
00-90	Pause time settable from 00 to 90 s.
92-99	Pause time settable from 2 to 9 min.
20 00	COR output operating mode NOTE: the signal given by the COR output can only be used if the "low power" mode is disabled (L 1 00)
00	STANDARD operation managed by parameter 79
01	Closed contact if the release handle is correctly closed (with the key turned to closed position). Open contact due to a fault: Motor released and/or key turned to open position.
02	Contact closed if the motor is powered by the mains or charged battery. Open contact due to a fault: Motor powered by low battery (voltage level set by par. 85) or with error alert bE L D (the control unit no longer accept commands).
03	Closed contact if none of the fault related situations 1 and 2 occurs. Open contact if at least one of the fault related situations 1 and 2 occurs
04	Closed contact if the gate is not completely open. Open contact if the gate is completely open.
05	Closed contact if the gate is not completely closed. Open contact if the gate is completely closed.
21 30	Setting automatic closing time The timer starts from the gate open state and continues for the set time. Once the set time is reached, the gate closes automatically. The timer count restarts if a photocell is triggered.
00-90	Pause time settable from 00 to 90 s.
92-99	Pause time settable from 2 to 9 min.
22 00	Enabling of management for opening with automatic re-closure exclusion If enabled, the exclusion of automatic re-closure only applies for the command selected via the parameter. For example: if you set 22 0 1, automatic re-closure is excluded following an AP command, but it is activated following a PP or PED command. NOTE: The command has open-stop-close or close-stop-open sequence activation function.
00	Disabled.
01	An AP (open) command activates the opening manoeuvre. With the gate fully open, automatic reclosing is excluded. Another AP (open) command activates the closure manoeuvre.
02	A PP (step mode) command activates the opening manoeuvre. With the gate fully open, automatic reclosing is excluded. Another PP (step mode) command activates the closure manoeuvre.
03	A PED (partial opening) command activates the partial opening manoeuvre. Automatic re-closure is excluded. Another PED (partial opening) command activates the closure manoeuvre.
27 03	Setting reverse time after activation of sensing edge or obstacle detection (crush prevention) This sets the reverse manoeuvre time after activation of the sensing edge or the obstacle detection system. The gate comes to a stop after reversal dues to activation of the sensing edge or obstacle detection system at the end of manoeuvre deceleration speed. As a result, the effective reversal manoeuvre time is slightly longer than the set time.
00-60	From 0 to 60 s.
30 05	Setting motor torque Increasing or decreasing the value of the parameter increases or decreases motor torque and, as a result, adjusts obstacle detection sensitivity. Use values below 03 ONLY for particularly lightweight installations not exposed to severe weather conditions (strong winds or very cold temperatures).
0 1-09	0 1 = -35%; 02 = -25%; 03 = -16%; 04 = -8% (reduced motor torque = increased sensitivity). 05 = default motor torque setting. 06 = +8%; 07 = +16%; 08 = +25%; 09 = +35% (increased motor torque = reduced sensitivity).
31 15	Setting obstacle impact force sensitivity If the reaction time to obstacle impact force is too long, reduce the value of the parameter. If the impact force exerted on obstacles is too high, reduce the value of parameter 30.
0 1-10	Low motor torque: 0 1 = minimum obstacle impact force ... 10 = maximum obstacle impact force N.B.: only use these settings if the medium motor torque values are not suitable for the installation.
1 1-16	Medium motor torque. Recommended setting for adjusting force settings correctly. 1 1 = minimum obstacle impact force ... 16 = maximum obstacle impact force.
17	70% of maximum motor torque, 1 s of reaction time. Sensing edge is compulsory.

18	80% of maximum motor torque, 2 s of reaction time. Sensing edge is compulsory.
19	Maximum motor torque, 3 s of reaction time. Sensing edge is compulsory.
20	Maximum motor torque, 5 s of reaction time. Sensing edge is compulsory.
33 04	Setting start acceleration during opening and closing
34 04	See chapter 13-14 "Special parameters for High Speed and Reversible series"
0 1-05	0 1= the gate accelerates rapidly at start of manoeuvre ... 05= the gate accelerates slowly and progressively at start of manoeuvre.
36 00	Enabling maximum torque boost at start of manoeuvre If this parameter is enabled, each time the motor starts a manoeuvre, maximum torque is produced for a maximum of 5 seconds, or for the time necessary for the gate to open by approximately 65 cm. N.B: in the case of High Speed motors, a motor boost mode is implemented for 2 seconds after each gate start, regardless of the setting of parameter 36.
00	Disabled.
0 1	Enabled at start of opening manoeuvre only (including position recovery). The motor starting current function is only enabled for closing manoeuvres if the gate position is known and the gate is at least 2 metres from the completely closed position.
02	Enabled for all starts (including position recovery).
37 00	Setting motor torque during position recovery Adjust motor torque with parameter 37 if, during position recovery, the values set with parameters 30 and 3 1 are insufficient to allow the gate to complete the manoeuvre. If position recovery is not completed, normal gate operation will not be resumed.
00	The response of the obstacle detection system depends solely on the values set for parameters 30 and 3 1.
0 1	The response of the obstacle detection system depends on the values set for parameters 30 and 3 1 and on the maximum current value stored during travel acquisition.
02	The response of the obstacle detection system is a 70% reduction in maximum torque for a period of 1 s.
03	The response of the obstacle detection system is a 80% reduction in maximum torque for a period of 2 s.
04	The response of the obstacle detection system is a 100% reduction in maximum torque for a period of 3 s.
05	The response of the obstacle detection system is a 100% reduction in maximum torque for a period of 5 s.
40 05	Setting opening and closing speed (%)
41 05	See chapter 13-14 "Special parameters for High Speed and Reversible series"
0 1-05	0 1= 60% minimum speed, 02= 70%, 03= 80%, 04=90%, 05= 100% maximum speed.
42 03	Setting end of manoeuvre constant approach speed Once deceleration is complete, the gate continues to the limit switch at constant speed. The distance is set with the parameters 13 and 14.
0 1-08	0 1= 250 RPM; 02= 300 RPM; 03= 350 RPM; 04= 400 RPM; 05= 450 RPM; 06= 500 RPM; 07= 550 RPM; 08= 600 RPM NOTE: The minimum and maximum approaching speeds vary according to the installed motor model. The settings are divided in constant size steps. Indicative values: BH30/800 from approximately 2 m/min to 5 m/min BH30 and BM30 HIGH SPEED from approximately 3 m/min to 8 m/min BH30 REVERSIBLE from approximately 2 m/min to 6 m/min
49 01	Setting number of automatic closure attempts after activation of sensing edge or obstacle detection (crush protection)
00	No automatic closure attempts.
0 1-03	From 1 to 3 automatic closure attempts. We recommend setting a value equal to or lower than the value set for parameter 42. Automatic closure is only performed if the gate is completely open.
50 00	Setting photocell mode during gate opening (FT1)
00	DISABLED. Photocell is not active or not installed.
0 1	STOP. The gate stops and remains stationary until the next command is received.
02	IMMEDIATE REVERSE. The gate reverses immediately if the photocell is activated during gate opening.

03	TEMPORARY STOP. The gate stops as long as the photocell is obstructed. The gate resumed opening when the photocell is cleared.
04	DELAYED REVERSE. The gate stops if the photocell is obstructed. The gate closes when the photocell is cleared.
5102	Setting photocell mode during gate closing (FT1)
00	DISABLED. Photocell is not active or not installed.
01	STOP. The gate stops and remains stationary until the next command is received.
02	IMMEDIATE REVERSE. The gate reverses immediately if the photocell is activated during gate closure.
03	TEMPORARY STOP. The gate stops as long as the photocell is obstructed. The gate resumed closing when the photocell is cleared.
04	DELAYED REVERSE. The gate stops if the photocell is obstructed. The gate opens when the photocell is cleared.
5201	Photocell (FT1) mode with gate closed This parameter is not visible if AB 02 , AB 03 or AB 04 is set.
00	If the photocell is obstructed, the gate cannot open.
01	The gate opens when an open command is received, even if the photocell is obstructed.
02	The photocell sends the gate open command when obstructed (usable only if L 100).
5300	Setting photocell mode during gate opening (FT2)
00	DISABLED. Photocell is not active or not installed.
01	STOP. The gate stops and remains stationary until the next command is received.
02	IMMEDIATE REVERSE. The gate reverses immediately if the photocell is activated during gate opening.
03	TEMPORARY STOP. The gate stops as long as the photocell is obstructed. The gate resumed opening when the photocell is cleared.
04	DELAYED REVERSE. The gate stops if the photocell is obstructed. The gate closes when the photocell is cleared.
5400	Setting photocell mode during gate closing (FT2)
00	DISABLED. Photocell is not active or not installed.
01	STOP. The gate stops and remains stationary until the next command is received.
02	IMMEDIATE REVERSE. The gate reverses immediately if the photocell is activated during gate closure.
03	TEMPORARY STOP. The gate stops as long as the photocell is obstructed. The gate resumed closing when the photocell is cleared.
04	DELAYED REVERSE. The gate stops if the photocell is obstructed. The gate opens when the photocell is cleared.
5501	Photocell (FT2) mode with gate closed This parameter is not visible if AB 02 , AB 03 or AB 04 is set.
00	If the photocell is obstructed, the gate cannot open.
01	The gate opens when an open command is received, even if the photocell is obstructed.
02	The photocell sends the gate open command when obstructed.
5600	Enable close command 6 s after activation of photocell (FT1-FT2) This parameter is not visible if AB 03 or AB 04 is set. NOTE: in the case of photocells being blanked during opening, the 6 secs. count starts when the wings are completely open. If the automation enters stand-by in the fully open position, the function is not managed (the photocells are not powered)
00	Disabled.
01	Enabled. When the photocell barrier FT1 is crossed, a close command is sent 6 seconds later.
02	Enabled. When the photocell barrier FT2 is crossed, a close command is sent 6 seconds later.
6001	Limit switch type selection NOTE: only the 'micro-switch' selection allows contact monitoring even during the stand-by phase, as the magnetic limit switch in stand-by is not powered. Correct selection allows the control unit to optimally manage changes in status (e.g. if a manual movement occurs after the automation has been unlocked)
00	Micro-switch limit switches (pure contact)
01	Magnetic limit switches (hall effect sensors)

65 05	Setting motor stop distance
0 1-05	0 1= faster deceleration/shorter stop distance ... 05= slower deceleration/longer stop distance.
71 01	Selecting installation position of motor relative to gate (seen from interior side) N.B.: in the event of a reset to restore the default parameters, this parameter must be set again manually.
00	Motor installed on left.
0 1	Motor installed on right.
73 00	Configuring sensing edge COS1
00	Sensing edge NOT INSTALLED.
0 1	NC contact (normally closed). The gate reverses only when opening.
02	Contact with 8k2 resistor. The gate reverses only when opening.
03	NC contact (normally closed). The gate always reverses.
04	Contact with 8k2 resistor. The gate always reverses.
12	Management of two 8k2 sensitive edges connected in parallel (total resistance 4k1). The gate reverses only when opening.
14	Management of two 8k2 sensitive edges connected in parallel (total resistance 4k1). The gate always reverses.
74 00	Configuring sensing edge COS2
00	Sensing edge NOT INSTALLED.
0 1	NC contact (normally closed). The gate reverses only when closing.
02	Contact with 8k2 resistor. The gate reverses only when closing.
03	NC contact (normally closed). The gate always reverses.
04	Contact with 8k2 resistor. The gate always reverses.
12	Management of two 8k2 sensitive edges connected in parallel (total resistance 4k1). The gate reverses only when opening.
14	Management of two 8k2 sensitive edges connected in parallel (total resistance 4k1). The gate always reverses.
76 00	Configuring radio channel 1 (PR1) N.B.: With ROGER TECHNOLOGY plug-in radio receiver board.
77 01	Configuring radio channel 2 (PR2) N.B.: With ROGER TECHNOLOGY plug-in radio receiver board.
00	STEP MODE.
0 1	PARTIAL OPENING
02	OPENING
03	CLOSING.
04	STOP.
05	Courtesy light. The output COR is managed from the remote control. The light remains lit as long as the remote control is active. The parameter 79 is ignored.
06	Courtesy light in step mode (PP). The output COR is managed from the remote control. The remote control turns the courtesy light on and off. The parameter 79 is ignored.
07	STEP MODE with confirmation for safety. ⁽¹⁾
08	PARTIAL OPENING with confirmation for safety. ⁽¹⁾
09	OPENING with confirmation for safety. ⁽¹⁾
10	CLOSURE with confirmation for safety. ⁽¹⁾

⁽¹⁾ To prevent gate manoeuvres caused by accidentally pressing a remote control button, confirmation is required to enable the command. Example: parameters 76 07 and 77 0 1 set:

- Pressing the CHA button on the remote control selects the step mode function, which must be confirmed within 2 seconds by pressing CHB on the remote control. Press CHB to activate partial opening.

78 00	Configuring flashing light frequency
00	The frequency is set electronically from the flashing light unit.
0 1	Slow flash.
02	Light flashes slowly when gate opens, rapidly when gate closes.

79 60	Selecting courtesy light mode N.B.: the parameter is not visible if par. 20 is different than 00
00	Disabled.
01	PULSE. The courtesy light illuminates briefly at the start of each manoeuvre.
02	ACTIVE. The light remains lit for the entire duration of the manoeuvre.
03-90	From 3 to 90 s. The light remains lit for the time period set after the manoeuvre is completed.
92-99	From 2 to 9 minutes. The light remains lit for the time period set after the manoeuvre is completed.
80 00	Clock contact configuration When the clock function is active, the gate opens and remains open. At the end of the programmed time set with the external device (clock), the gate closes.
00	When the clock function is active, the gate opens and remains open. Any command signal received is ignored.
01	When the clock function is active, the gate opens and remains open. Any command signal received is accepted. When the gate returns to the completely open position, the clock function is reactivated.
81 00	Enable safeguarded gate closure/opening Enabling this parameter ensures that the gate is not left open due to an incorrect and/or accidental command. This function is NOI enabled if: <ul style="list-style-type: none"> • the gate receives a STOP command; • the sensing edge intervenes, detecting an obstacle in the same direction in which the function is enabled. If instead the sensing edge detects an obstacle during the movement opposite to the guaranteed one, the function is maintained active. • the number of closure attempts set by parameter A2 has been reached; • the acquired position is lost (perform position recovery, see chapter 19).
00	Disabled. The parameter B2 is not displayed.
01	Guaranteed closing enabled. After a period of time set with parameter B2 , the control unit signals a 5 second warning with the flashing light, regardless of the parameter A5 , and then closes the gate.
02	Guaranteed closing and opening enabled. If the gate is closed as a result of a step mode command, after a period of time set with parameter B2 , the control unit signals a 5 second warning with the flashing light (regardless of the parameter A5), and then the gate closes. If the gate is stopped by the obstacle detection system during a closure manoeuvre, the gate closes after a period of time set with parameter B2 . If the gate is stopped by the obstacle detection system during an opening manoeuvre, the gate closes after a period of time set with parameter B2 .
82 03	Setting safeguarded closure/opening activation time N.B.: this parameter is not visible if the value of parameter B1 = 00.
02-90	Wait time settable from 2 to 90 s.
92-99	Wait time settable from 2 to 9 min.
85 03	Selection of the battery operation management Setting a value different than 00 a battery voltage level check is activated. The desired operation type can be selected via parameter B6 and an error alert can be activated through the COR output via parameter 20 .
00	The control unit always accepts commands until the battery is completely exhausted. When the battery voltage drops to the minimum allowed, the message bEL 0 appears on the display (20V $\overline{---$ with B71/BC battery charger; 23.7V $\overline{---$ with B71/PBX external battery charger). The control unit no longer accepts commands.
01	The command becomes active when the battery voltage drops to the minimum threshold (22V $\overline{---$ with battery charger B71/BC; 24.6V $\overline{---$ with external charger B71/PBX)
02	The command becomes active when the battery voltage drops to the medium threshold (23V $\overline{---$ with battery charger B71/BC; 25V $\overline{---$ with external charger B71/PBX)
03	The command becomes active when the battery voltage drops to the maximum threshold (24V $\overline{---$ with battery charger B71/BC; 25.4V $\overline{---$ with external charger B71/PBX)
86 00	Selecting the battery operation limitations N.B.: the parameter is visible only if par. B5 is different than 00
00	There is no limitation for the commands when the battery voltage drops under the selected threshold. An error alert may be activated via the COR output (if parameters B5 and 20 are adequately set).
01	When the battery voltage drops under the threshold selected with par. B5 , the control unit accepts only opening commands and does not perform closing.
02	When the battery voltage drops under the threshold selected with par. B5 , after a 5 s pre-flashing, the control unit automatically opens the barrier's boom and accepts only a closing command.
03	It accepts only closing commands (if the ORO input is active, it accepts closing commands only if B0 01).

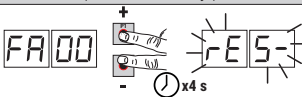
04	When the battery voltage drops to the threshold selected with par. 85 the control unit, after a prelampping of 5s, automatically closes the gate and accepts only one opening command.
87 00 Selection of the battery type and consumption reduction	
00	Battery 24V $\overline{---$ (2x12V $\overline{---$) with B71/BC. Acceleration/deceleration/speed reduction enabled, to increase the battery life.
01	Battery 24V $\overline{---$ (2x12V $\overline{---$) with B71/BC. No performance reduction, maximum battery consumption.
02	Battery 24V $\overline{---$ (2x12V $\overline{---$) with external charger B71/PBX. Acceleration/deceleration/speed reduction enabled, to increase battery life.
03	Battery 24V $\overline{---$ (2x12V $\overline{---$) with external charger B71/PBX. No reduction in performance. Maximum battery consumption.
88 00 Cyclical activation (test mode) The automation system is activated in opening mode at intervals defined by the parameter; automatic closing must be selected (par. A2 and par. 2 I).	
00	Disabled.
0 1-90	Opening command activated every 1" ... 90" NOTE: While the cyclical activation command concerns the opening movement, it is controlled so as to allow a complete opening-pause-closing cycle before starting again; consequently, if the time set in par. 88 is less than the time to complete the cycle, the control unit waits for the complete closure, and from that moment, it gives another opening command, after a time equivalent to the parameter value E.g. opening time = closing time = 15"; pause time = 2" By setting par. 88=33 it starts a complete cycle every 33" By setting par. 88= 15 it completes a cycle, remains completely closed for 15" and then starts over, so it starts a complete cycle every 32" + 15" = 47"
9 1-99	Opening command activated every 1min ... 9 min.
89 00 Enabling parameter management of the SLAVE control unit using B74/BCONNECT inserted on the MASTER control unit By inserting a B74/BCONNECT on the MASTER control unit, it is possible to use the parameter consultation, modification and backup menus also for the SLAVE control unit, setting the value 0 1 on the MASTER control unit. ATTENTION! Once the operations are complete, remember to set the value back to 00.	
00	Disabled.
0 1	on the MASTER control unit allows: - displaying the parameters and editing the individual SLAVE parameters - saving the backup of the parameters taken from the SLAVE control unit to B-CONNECT
L0 00 Enabling serial communication	
00	Disabled
0 1	Enabling module B74/BCONNECT
02	Enabling debug board (internal use)
L1 04 Configuration of 'low power stand-by' mode NOTE: 'low power stand-by' is activated after inactivity that lasts for the preset time, i.e. with the automation stopped and no activation of commands or keys on the display. With the automation fully open and paused for automatic reclosing, stand-by is not activated, as it is in any case an active phase of automatic operation (regulated by par. A2 and 2 I). Similarly, the time countdown for guaranteed closing/opening (par. B 1 and B2) is considered an active phase, so stand-by is not activated.	
00	"low power" mode disabled
0 1	Stand-by activation after 5 minutes of inactivity
02	Stand-by activation after 10 minutes of inactivity
03	Stand-by activation after 15 minutes of inactivity
04	Stand-by activation after 20 minutes of inactivity
FA 00 Restoring factory default values NOTE This procedure is only possible if NO data protection password is set.	
FA 00	<div style="display: flex; align-items: center;">  <div style="margin-left: 20px;"> <p>Warning! Restoring default settings cancels all settings made previously except for parameter A0, A 1, G0, 1 I, B6, B7, B9, L0, L 1: after restore, check that all parameters are suitable for the installation.</p> <ul style="list-style-type: none"> • Press and hold the PLUS + and MINUS - button until the unit switches on. • The display flashes after 4 s rE5- . </div> </div> <p>• The default factory settings have now been restored.</p>
Note: it is possible to reset the parameters in a second way: when the control unit is switched on, before the firmware version appears on the display, press and hold down the ▲ (UP ARROW) and ▼ (DOWN ARROW) buttons for 4s.	

Identification number The identification number consists of the values of the parameters from $n0$ to $n5$. N.B.: The values shown in the table are indicative only.	
$n0$ 01	HW version.
$n1$ 23	Year of manufacture.
$n2$ 45	Week of manufacture.
$n3$ 67	Example: 0 1 23 45 67 89 0 1 23
$n4$ 89	
$n5$ 01	
$n6$ 23	
$n6$ 23	FW sequential version.

View manoeuvre counter The number consists of the values of the parameters from $o1$ to $o4$ multiplied by 100. N.B.: The values shown in the table are indicative only.	
$o1$ 01	
$o0$ 23	
$o1$ 45	
$o0$ 23	Manoeuvres performed. Example: 0 1 23 45 x100 = 1.234.500 manoeuvres.
$o1$ 45	

View manoeuvre hour counter The number consists of the values of the parameters from $h0$ to $h1$. N.B.: The values shown in the table are indicative only.	
$h0$ 01	
$h1$ 23	
$h1$ 23	Manoeuvre hours. Example: 0 1 23 = 123 hours.

View control unit days on counter The number consists of the values of the parameters from $d0$ to $d1$. N.B.: The values shown in the table are indicative only.	
$d0$ 01	
$d1$ 23	
$d1$ 23	Days with unit switched on. Example: 0 1 23 = 123 days.

Password Setting a password prevents unauthorised persons from accessing the settings. With password protection active ($CP=01$), parameters may be viewed, but the values CANNOT be modified. <u>Only a single password is used to control access to the gate automation system.</u> WARNING: Contact the Technical Support Service if you lose your password.	
$P1$ 00 $P2$ 00 $P3$ 00 $P4$ 00	Password activation procedure: <ul style="list-style-type: none"> Enter the desired values for parameters $P1$, $P2$, $P3$ and $P4$. Use the UP ▲ and/or DOWN ▼ buttons to view the parameter CP. Press and hold the + and - buttons for 4 seconds. The display flashes to confirm that the password has been saved. Switch the control unit off and on again. Check that password protection is activated ($CP=01$). Temporary unlock procedure: <ul style="list-style-type: none"> Enter the password. Check that $CP=00$. Password cancellation procedure: <ul style="list-style-type: none"> Enter the password ($CP=00$). Save the values $P1 = 00$, $P2 = 00$, $P3 = 00$, $P4 = 00$ Use the UP ▲ and/or DOWN ▼ buttons to view the parameter CP. Press and hold the + and - buttons for 4 seconds. The display flashes to confirm that the password has been cancelled (the values $P1$ 00, $P2$ 00, $P3$ 00 and $P4$ 00 indicate that no password is set). Switch the control unit off and on again.

CP 00	Changing password
00	Protection deactivated.
01	Protection activated.

13 Special parameters for High Speed series



The High Speed series is a family of digital brushless high speed sliding motor units for sliding gates weighing up to 600 kg (**BH30/503/HS - BH30/504/HS - BH30/603/HS - BH30/604/HS**) and up to 400 kg (**BM30/300/HS**) and dedicated exclusively to residential applications.

High Speed technology makes it possible for the automation system to operate 100% faster than a conventional system, and allows independent management of speed, acceleration, deceleration and the safety devices used in the system.

Note: As the mechanics of the gate is unknown, to guarantee the maximum safety of the installation, we recommended to use sensitive edges.

The additional parameters for enabling High Speed technology are indicated as follows.

R103 R105	Selecting automation system model This parameter is factory configured by ROGER TECHNOLOGY. WARNING! The parameter is already configured by default to enable use of the of motor in high speed mode. If this parameter is modified, all the specific motor functions relative to high speed mode will no longer be available. The automation system will no longer function effectively and it will not be possible to diagnose faults. N.B.: in the event of a reset to restore the default parameters, this parameter must be set again manually.
01	BH30/603 - BH30/604
02	BH30/803- BH30/804
03	BH30/503/HS - BH30/504/HS - BH30/603/HS - BH30-604/HS
04	BM30/400
05	BM30/300/HS
06	BH30/804/R
1104	Setting deceleration during opening
1204	Setting deceleration during closing
01-05	01= the gate decelerates near the limit switch ... 05= the gate decelerates long before the limit switch.
3304	Setting start acceleration during opening
3404	Setting start acceleration during closing
01-05	01= the gate accelerates rapidly at start of manoeuvre ... 05= the gate accelerates slowly and progressively at start of manoeuvre.
4005	Setting opening speed (%) N.B.: the speed setting range is subdivided into 5 equal segments.
4105	Setting closure speed (%) N.B.: the speed setting range is subdivided into 5 equal segments.
01-05	01= 10 m/min (minimum speed) ... 05= 24 m/min (maximum speed).



N.B.: to set the constant speed deceleration space, see parameters *13* and *14* on chapter 12.

14 Special parameters for Reversible series



The BH30/R series (REVERSIBLE) is a family of digital brushless motor units for sliding gates weighing up to 800 kg (**BH30/804/R**) and dedicated exclusively to residential and industrial applications. REVERSIBLE technology makes it possible to open and close the gate, without power supply, without releasing the motor even.

When the gate is moved manually, in the absence of supply voltage, the rotation of the motor supplies power to the control panel, the display turns ON and the message "SELF" appears. **WARNING!** Move the gate by hand with moderation.

The control unit allows independent management of speed, acceleration, deceleration and the safety devices used in the system.

During normal operation (including operation under battery power), the control unit applies a sufficient braking force to impede manual movement of the gate.

As a result, prolonged operation may drain the battery when operating under battery power.

If the braking force applied is not sufficient to impede manual movement of the gate and a gate movement of more than 3 cm is detected, the control unit initiates a position recovery procedure (see chapter 19).

NOTE: Even though it is a REVERSIBLE unit, the motor is equipped with a lock release system.

The additional parameters for enabling REVERSIBLE technology are indicated as follows.

R106	Selecting automation system model This parameter is factory configured by ROGER TECHNOLOGY. WARNING! The parameter is already configured by default to enable use of the of motor REVERSIBLE mode. If this parameter is modified, all the specific motor functions relative to REVERSIBLE mode will no longer be available. The automation system will no longer function effectively and it will not be possible to diagnose faults. N.B.: in the event of a reset to restore the default parameters, this parameter must be set again manually.
01	BH30/603 - BH30/804
02	BH30/803 - BH30/804
03	BH30/503/HS - BH30/504/HS - BH30/603/HS - BH30/604/HS
04	BM30/400
05	BM30/300/HS
06	BH30/804/R
1104	Setting deceleration during opening
1204	Setting deceleration during closing
01-05	01= the gate decelerates near the limit switch ... 05= the gate decelerates long before the limit switch.
3304	Setting start acceleration during opening
3404	Setting start acceleration during closing
01-05	01= the gate accelerates rapidly at start of manoeuvre ... 05= the gate accelerates slowly and progressively at start of manoeuvre.
4005	Setting opening speed N.B.: the speed setting range is subdivided into 5 equal segments.
4105	Setting closure speed N.B.: the speed setting range is subdivided into 5 equal segments.
01-05	01= 7 m/min (minimum speed) ... 05= 20 m/min (maximum speed).



N.B.: to set the constant speed deceleration space, see parameters 13 and 14 on Chapter 12.

15 Safety input and command status (TEST mode)

With no currently active commands, press the TEST button and check the following:

DISPLAY	POSSIBLE CAUSE	ACTION BY SOFTWARE	PHYSICAL CORRECTIVE ACTION
885b (00 Sb)	The release handle is open.	-	Close the release handle and turn the key to the close position. Check that the release contact is connected correctly.
88 15	The safety STOP contact is open.	-	Install a STOP button (NC) or jumper the ST contact with the COM contact.
88 13	Sensing edge COS1 not connected or incorrectly connected.	Set the parameter 73 00 if not used or to disable	Jumper contact COS1 with contact COM, if not used or to disable
88 12	Sensing edge COS2 not connected or incorrectly connected.	Set the parameter 74 00 if not used or to disable	Jumper contact COS2 with contact COM, if not used or to disable
88 11	Photocell FT1 not connected or incorrectly connected.	Set the parameter 50 00 e 51 00 if not used or to disable	Jumper contact FT1 with contact COM, if not used or to disable. Check connection referring to relative connection diagram.
88 10	Photocell FT2 not connected or incorrectly connected.	Set the parameter 53 00 e 54 00 if not used or to disable	Jumper contact FT2 with contact COM, if not used or to disable. Check connection referring to relative connection diagram.
88FE	Both limit switches in open contact state or not connected.	-	Check connection of limit switches.
88FR	Gate is at gate closed limit switch.	If the limit switch state indicated is incorrect, check the setting of parameter 7 l.	-
	Gate open limit switch absent or not connected.	-	Check connection of limit switches.
88FC	Gate is at gate closed limit switch.	If the limit switch state indicated is incorrect, check the setting of parameter 7 l.	-
	Gate closed limit switch absent or not connected.	-	Check connection of limit switches.
88nC	No RS485 communication between MASTER and SLAVE control units.	See instructions for MASTER/SLAVE management.	See instructions for MASTER/SLAVE management.
PP00	If occurs with no voluntary command, the contact (N.O.) may be faulty or one of the buttons may be incorrectly connected.	-	Check PP - COM contacts and connections to buttons.
CH00		-	Check CH - COM contacts and connections to buttons.
AP00		-	Check AP - COM contacts and connections to buttons.
PE00		-	Check PED - COM contacts and connections to buttons.
OR00	If occurs with no voluntary command, the contact (N.O.) may be faulty or the timer may be incorrectly connected.	-	Check ORO - COM contacts. Contact must not be jumpered if not used.

N.B: press TEST to exit TEST mode.

We recommend troubleshooting safety device and input status errors with "corrective action by software" only.

16 Alarms and faults

PROBLEM	ALARM	POSSIBLE CAUSE	ACTION
The gate does not open or close.	POWER LED off	No power.	Check power cable.
	POWER LED off	Fuses blown.	Replace fuses. Always disconnect from mains power before removing fuses.
	OFSt	Input mains power voltage fault. Control initialisation failed.	Disconnect from mains power, wait 10 seconds then reconnect to the mains and switch on. If the problem persists, contact your local authorized dealer for verification and possible assistance. Pressing the TEST button it is possible to hide the alarm temporarily and consult the control unit's parameters.
	PrDt	Overcurrent detected in inverter.	Press the TEST button twice or perform 3 command requests in succession.
	dAtA	Travel data acquisition error.	Check that open and closed limit switches are positioned correctly. Press TEST and check if any safety devices are in alarm state. Repeat acquisition procedure.
		Calibration procedure failed.	Allow the indicated calibration times to elapse during self-acquisition. Check that PHAS is shown flashing on the display before closing the release lock cover. Repeat acquisition procedure.
	Not	Motor not connected.	Check the motor cable.
	FE	Both limit switches activated.	Check connections of limit switches or check for foreign objects in limit switch blocks.
	Example: ISEE Z IEE	Configuration parameter error.	Set configuration value correctly and save.
	EnE 1	Encoder not connected.	Check connection to encoder. Replacing the encoder is recommended if the problem persists.
	EnE3	Severe encoder malfunction.	Press TEST button. If the error code is displayed again, switch off the controller unit, wait 5 seconds and switch on again. Replace the encoder if the problem persists.
	EnE5 (EnE5)	Encoder malfunction.	Press TEST button. Replace the encoder if the problem persists.
		Insufficient power supply	If the unit contains dirt, moisture, insects or other foreign matter, disconnect from mains power and clean the board and the encoder. Replace the encoder if the problem persists.
		Batteries functioning	The batteries are almost flat.
	EnEB	Encoder calculation error.	Repeat acquisition procedure.
	tENP	Inverter thermal overload circuit breaker tripped.	Function is restored automatically within 2 min.
	SEnS	Motor power control anomaly detected	If the problem persists, replace the control unit.
	btLO (btLO)	Flat batteries.	Wait for mains power to be restored.
	CO1	No RS485 serial communication between MASTER control unit and SLAVE control unit.	Check connection to terminals COM-LNA-LNB.
			Check settings of parameter AD. Check that battery kit is installed on both MASTER and SLAVE control unit.
	CO2	Serial communication interference: two MASTER controllers detected.	Check settings of parameter AD.
	CO3	Parameter configuration transfer error between MASTER and SLAVE.	Check connection to terminals COM-LNA-LNB.
	CO4	Incompatibility between firmware versions of controller units.	Check parameter n7. The connected control units must have the same RS485 communication version. Contact the technical assistance.
StoP flashing	Release device open.	Close the release handle and turn the key to the close position. Check that the release contact is connected correctly.	

PROBLEM	ALARM	POSSIBLE CAUSE	ACTION	
The gate does not open or close.	<i>noPH</i>	Motor control anomaly detected	Repeat the acquisition procedure. If the problem persists, replace the control unit.	
The gate does not open or close.	<i>noPH</i>	Problems at the encoder circuit or at the connection cable.	Check the integrity of the connection cable. Disconnect and reconnect the power supply. Give a command (opening / step-by-step, ...). If <i>noPH</i> is NOT displayed, repeat the acquisition procedure. If <i>noPH</i> is displayed again, contact the technical service department.	
Acquisition procedure does not complete correctly.	<i>noPH</i>	Motor calibration failed.	Repeat acquisition procedure. If the problem persists, check the cable connecting the encoder to the motor. Check if release handle is open. Check that the motor turns without impediment. Contact technical support in case of any problems. Check that the mains voltage is correct and that the mains cable cross-section is adequate.	
		<i>RPPE</i>	TEST button pressed accidentally.	Repeat acquisition procedure.
			Safety devices in alarm state.	Press the TEST button and check the safety device/s in alarm state and the connections of the safety devices.
		<i>APPL</i>	Excessive voltage drop.	Repeat acquisition procedure. Check mains voltage.
	Incorrect setting of parameters $\exists D$ and $\exists I$.		Adjust parameters $\exists D$ and $\exists I$ correctly for the weight and speed of the gate leaf.	
	Travel length error.		Move gate into completely closed position (FC limit switch signal must be active) and repeat the procedure. Check cable of limit switches. Replace the cable if the problem persists. Reset default controller unit parameters and repeat the procedure. Stroke length less than the minimum allowed: increase the length.	
	<i>APPN</i>	Maximum permitted travel length exceeded	Reduce the ride. Contact technical assistance (travel exceeding the maximum allowed by the technical characteristics).	
Remote control has limited range and does not work while automated gate is moving.	-	The radio transmission is impeded by metal structures and reinforced concrete walls.	Install the antenna outside.	
The flashing light is not working.	-	Flat batteries.	Replace the transmitter batteries.	
The flashing light is not working.	-	Bulb / LED blown or flashing light wires disconnected.	Check LED circuit and/or connector wires.	
Gate open indicator lamp does not work.	-	Bulb blown or wires disconnected.	Check the bulb and/or wires.	
Gate does not perform desired manoeuvre.	-	Incorrect setting of parameter $\exists I$.	Select the correct installation position with parameter $\exists I$.	
The control unit is switched off and does not start.	-	F2 fuse blown due to overvoltage.	Replace the 2A F2 fuse.	
	<i>SELF</i>	Only for BH30/804/R. The gate is moved by hand without being unlocked, without mains and/or battery voltage	WARNING: if B71/BC is used, check the correct connection of the battery charger to the control unit (the red cable [+] must be connected to the POWER IN terminal 5, the black cable [-] must be connected to the POWER IN terminal 4). Otherwise, the manual manoeuvre will not be performed correctly.	
The control unit does not accept commands.	<i>SELF</i> <i>ALIN</i>	Incorrect connection of the battery charger to the control unit. After 5 s the display shows ALIM to confirm the incorrect connection of the POWER-IN terminal strip.	Reverse the connection of the (+) and (-) wires on the POWER IN terminal strip of the control unit (see battery connection at page 2). By pressing the TEST button, the error can be temporarily hidden to consult the control unit parameters.	
"Low power" mode does not activate	<i>noLP</i>	B70/MODLP damaged / relay contact stuck.	Control exercised by H93/RX2LP/1 faulty. Wiring between H93/RX2LP/1 and B70/MODLP defective.	
Transformer incorrectly switched off by B70/MODLP	<i>noEr</i>	B70/MODLP damaged / relay contact stuck.	Control exercised by H93/RX2LP/1 faulty. Wiring between H93/RX2LP/1 and B70/MODLP defective.	

N.B.: Press the TEST button to temporarily cancel the alarm.
The next time a command is received, the alarm reappears on the display if the problem has not been resolved.

17 Procedural verifications - INFO Mode

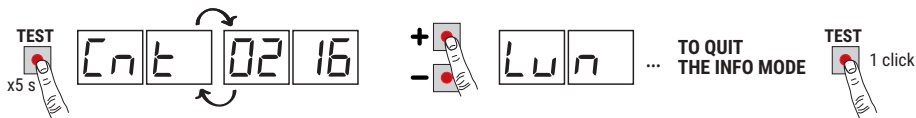

INFO mode may be used to view certain parameters measured by the **B70/1DC** controller. Press and hold the TEST button for 5 seconds from the "View command signals and safety devices" mode with the motor stationary.

The control unit displays the following parameters and the corresponding measured values in sequence:

Parameter	Function
<i>P3.00</i>	View for 3 s the firmware version of the control unit.
<i>CnE</i>	Displays the position of MOTOR, expressed in revolutions and relative to total length, at the time of the test. (example: <i>0.113</i> = motor installed on the left <i>71.00</i> ; <i>0.113</i> = motor installed on the right <i>71.01</i>).
<i>LUn</i>	View total length of programmed travel of MOTOR, in motor revolutions.
<i>rPM</i>	View motor speed of MOTOR, in revolutions per minute (rPM).
<i>AMP</i>	View current absorption of motor, in Amperes (e.g.: <i>001.1</i> = 1,1 A ... <i>016.5</i> = 16,5 A). If the MOTOR is stationary, the current absorption value is 0. Activate a command function to test current absorption.
<i>bUS</i>	System OK indicator. To check for overloading (e.g.: too many utilities connected to 24 V output) or if the mains voltage is too low, compare the parameters read with values indicated as follows with the motor stationary: mains voltage = 230 V~ (nominal), <i>bUS</i> = <i>28.5</i> mains voltage = 207 V~ (-10%), <i>bUS</i> = <i>25.5</i> mains voltage = 253 V~ (+10%), <i>bUS</i> = <i>31.5</i>
<i>ENP</i>	Display current, expressed in Amperes, used to compensate for strain detected by MOTOR due, for example, to low external temperatures (e.g.: <i>0</i> = 0 A ... <i>4</i> = +6 A). At the beginning of a manoeuvre from the completely open or completely closed position, if the control unit detects a strain higher than the value stored in its memory during the travel acquisition cycle, the controller automatically increases the current delivered to MOTOR.
<i>RSC</i>	Display current threshold, expressed in Amperes, at which the obstacle detection function (crush prevention) of MOTOR is triggered. This value is calculated automatically by the controller in relation to the settings of parameters <i>30</i> and <i>31</i> . For the motor to function correctly, <i>AMP</i> must always be lower than the value <i>RSC</i> .
<i>ti n</i>	Indicates time taken by MOTOR to detect an obstacle, as set with parameter <i>31</i> , in seconds. E.g. <i>1.000</i> = 1 s / <i>0.120</i> = 0.12 s (120 ms). Ensure that the manoeuvre time is more than 0.3 s.
<i>UP</i>	If the control unit is capable of identifying the position of the gate when the test is conducted, the following is shown on the display: <i>UP _ _</i> position known, normal operation. <i>UP L _</i> position unknown, position recovery in progress.
<i>OC</i>	Indicates the state of the automation system (open/closed). <i>OC OP</i> automation system opening (motor active). <i>OC CL</i> automation system closing (motor active). <i>OC -0</i> automation system completely open (motor not active). <i>OC -C</i> automation system completely closed (motor not active).
<i>UF</i>	<i>UF U _</i> mains voltage too low or overload. <i>UF _ H</i> motors overcurrent.
<i>nPE</i>	Displays the number of thermal protection interventions of the inverter. If it displays a number different from 0000, check that there are no excessive stress points and if the leaf, coming onto mechanical stops, does not activate the limit switch. Check the settings of parameters <i>30</i> and <i>31</i> .
<i>Hibu</i>	Displays information about the electronic voltage limiter (ROGER TECHNOLOGY's TECHNICAL ASSISTANCE ONLY).
<i>nsEA</i>	Displays a number which indicates the status of the control unit (INTERNAL USE - ROGER TECHNICAL ASSISTANCE)
<i>rsEA</i>	Displays a number which indicates the status of the SLAVE control unit (INTERNAL USE - ROGER TECHNICAL ASSISTANCE) and visible only on the MASTER control unit; on the SLAVE control unit, --- is always displayed.
<i>ErrL</i>	Number of RS485 communication errors (it gets reset by pressing "arrow down" ▼): this could highlight problems at board circuit level.
<i>ErrC</i>	Number of communication protocol errors (it gets reset by pressing "arrow down" ▼). It can highlight: • problems at connection cable level LNA/LNB/COM (reduced section, excessive length, closeness to cables with switching loads) • difficulties in communicating with the SLAVE control unit.

- Use the + / - buttons to scroll through the parameters. When the last parameter in the sequence is reached, press the - button to return through the previous parameters.
- In INFO mode, the automation system may be activated to test operation in real time.
- Press and hold the TEST button for a few seconds to exit INFO mode.

17.1 B74/BCONNECT mode

Use of the B74/BCONNECT must be enabled by setting par.L0=0 1; by default this parameter is 00 (disabled). The use of the device requires disabling the low-power management (L 1 00), as described in section 9.4. By inserting **B74/BCONNECT** in the **WiFi** connector, all the functions are managed through internet browser and devices such as smartphones, tablets, PCs, exploiting WiFi communication, tablet, PC, all the functionalities of the central unit are managed, using the WiFi communication.



For further information consult the installation manual of the connection module **B74/BCONNECT** connection module.

"Remote assistance" mode

Allows access and therefore the management of all the data of the control unit only in cloud mode and therefore with remote management.

When remote assistance is enabled, the message **ASCC** (assistance connect controlled) appears on the display. By pressing the **TEST** button this message disappears for 10 seconds, and it is possible to access the parameters and other functions of the display.

After 30 minutes the display goes into stand-by, if the display is awakened by pressing a key the flashing **ASCC** reappears.

"Emergency operation" mode

This mode is used to exclude motor and safety alarms (e.g. photocells and sensitive edges), allowing the automation to open and close at low speed and with the operator present, with movement of the leaves only in the presence of a persistent command (when the command is released, the leaves stop).

Emergency operation is indicated by activation of the flashing light at a higher frequency.

Two types of "emergency" mode are possible: residential or condominium.

1) **residential** (flashing **L-ES** display indication): the PP command (from the terminal board or radio control) is initially managed as an opening command; only when complete opening has been reached will activation of the command send it to closing. Only when complete closure has been achieved will the command be able to open again.

2) **condominium** (flashing **L-EM** display indication): the PP command is initially managed as an opening command, but once it has been fully opened the leaves no longer close.

In this mode the display stand-by is not activated, always indicating the mode in progress.

By pressing the **TEST** button this message disappears for 10 seconds, and it is possible to access the parameters and other functions of the display.

ASCC	"Remote assistance" mode enabled
L-ES	"Residential emergency operation" mode enabled
L-EM	"Condominium emergency operation" mode enabled

18 Mechanical release

In the event of a fault or mains power loss, the gate may be released and opened manually. For systems with BH30/804/R the gate can be moved by hand without unlocking it.

If the gate releases with the controller unit powered, the message **5E0P** flashes on the display.



For further information, refer to the locking/release operation in the manual of the **BH30** or **BM30** automation system.

- When the release system is restored to the normal operating position, if the gate is not completely open or completely closed the next time a command is received, the control initiates a position recovery procedure (see chapter 19).
- Activating one of the two limit switches immediately reacquires the position.

19 Position recovery mode

After a mains power outage or after mechanically releasing the gate, if the gate is not completely open or completely closed the next time a command is received, the control initiates a position recovery procedure:

- The gate starts a low speed manoeuvre.
- The flashing light flashes with a different duty cycle than normal (3 s on, 1.5 s off).
- The control unit recovers the installation data during this procedure. **Warning!** During this procedure, do not use any controls until one of the two limit switches is reached.
- Activating one of the two limit switches immediately reacquires the position.

20 Initial testing



The testing must be performed by qualified technical personnel.

The installer is required to measure impact forces and select on the control unit the appropriate speed and torque values to ensure that the motorised door or gate remains within the limits defined by the standards EN 12453 and EN 12445.

Make sure that the provisions in "GENERIC WARNINGS" are observed.

- Turn on the power supply.
- Check that all connected controls are working correctly.
- Check that the release handle works correctly. The message **5EOP** must flash on the display.
- Check travel and deceleration.
- Check that the impact force is correct, in compliance with EN 12453 and EN12445.
- Check that the safety devices are activated correctly.
- If the battery kit is installed, disconnect from mains and check that the batteries are working.
- Disconnect from mains power and disconnect the batteries (if used), then reconnect. Starting with the gate stopped in an intermediate position, check that the position recovery procedure is completed correctly for both the open and closed positions.
- Check that the limit switches are set correctly and function correctly. Adjust the position of installation of the motor if necessary.
- Check that there is a gap of at least 2-3 cm between the gate and the mechanical stop at the end of the manoeuvre.
- **Only for BH30/804/R.** Check that without mains or battery voltage, when moving the leaf by hand, the control unit is switched on and that the display shows the "SELF" message.
- **Only for BH30/804/R.** If there are batteries, disconnect the mains power and check that the display shows **BATE**. If **SELF** is displayed followed by **ALIN**, change the red and black cables connection to the POWER-IN terminal strips, as indicated in fig 2.

Declaration CE of Conformity

The undersigned Dino Florian, legal representative of Roger Technology - Via Botticelli 8, 31021 Mogliano V.to (TV) DECLARES that the **B70/1DC** digital control unit is compliant with the provisions established by Community directives:

- 2014/35/UE LVD Directive
- 2014/30/UE EMC Directive
- 2014/53/UE RED Directive
- 2011/65/UE RoHS Directive

and that all the standards and/or technical requirements indicated as follows have been applied:

EN 61000-6-3
EN IEC 61000-6-2
EN 60335-1

Place: Mogliano V.to

Date: 02/05/2016

Signature



ROGER TECHNOLOGY
Via S. Botticelli 8 • 31021 Bonisiolo di Mogliano Veneto (TV) • ITALIA
P.IVA 01612340263 • Tel. +39 041.5937023 • Fax. +39 041.5937024
info@rogertechnology.it • www.rogertechnology.com